

Eaton® Heavy-Duty Clutches CLSM0200 EN-US

April 2017

Self-Adjust Advantage®
Easy-Pedal Advantage®
Evertough Self-Adjust
Manual Adjust
ValueClutch™
UltraShift® DM
UltraShift® PLUS ECA
Clutch

Roadranger

Warning & Cautions 1**Clutch Service Procedures**

Advantage® Self-Adjusting Clutches	2
Clutch Removal	2
Clutch Installation	3
Clutch Set-up	11
Clutch Troubleshooting Procedures	15
Clutch Resetting Procedures	17

Easy-Pedal Advantage® Manual Adjust Clutches ...	21
Clutch Removal	21
Clutch Installation	22
Install Clutch to Flywheel	24
Clutch Set-up	29

14" Cast Clutches	34
Clutch Set-up	34

Evertough®, Value Clutch, Reman Self-Adjust Clutches	39
Clutch Removal	39
Clutch Installation	40
Clutch Set-up	47
Clutch Troubleshooting Procedures	51
Clutch Resetting Procedures	53

Evertough®, Value Clutch, Reman Manual Adjust Clutches	57
Clutch Removal	57
Clutch Installation	58
Install Clutch to Flywheel	60
Clutch Set-up	68

UltraShift® DM Heavy-Duty Clutch	73
Clutch Removal	73
Clutch Installation	75
Install Clutch to Flywheel	77
Clutch Recalibration	81

ECA Clutch	83
Clutch Removal	83
Clutch Installation	85
Install Clutch to Flywheel	87
Clutch Lubrication	92
Clutch Adjustment	93
Grease Interval Count Reset	94
Clutch Resetting Procedures	96

Low Capacity Inertia Brake Wear Life Measurement ..	99
---	----

Appendix

General Information	99
Hydraulic Linkage	100
General Information	100
General Clutch Information	104
Factors That Affect Clutch Performance	109
Preventive Maintenance Overview	112
Grease Compatibility – Eaton Clutch Products	113
Clutch Guide for Eaton Clutch Products	117
Eaton Clutch Products	117
Eaton Clutch Performance Evaluation and Set-up	122
Validating Clutch Release Bearing Travel with a Clutch Brake	122
Installing Clutch Inspection Hand Hole Cover	123
Machining of Pressure Plate and Intermediate Plate of 2250 lb-ft Rated Clutches	125

Warning & Cautions

Repair Warnings

 **Warning:** The major cause of clutch failure is excessive heat. Excessive heat generated between the flywheel, driven discs, intermediate plate and pressure plate can cause the metal to flow and the material to be destroyed. If this occurs, the clutch can burst, which can cause property damage, serious bodily injury or death. In order to prevent clutch failure resulting from excessive heat:

1. Do not exceed recommended vehicle loads.
2. The clutch should only be used for the recommended applications.
3. Drivers should be properly trained in starting, shifting and operating the clutch.
4. Drivers should report erratic clutch operation as soon as possible to permit maintenance personnel to inspect, adjust or lubricate as required.
5. Mechanics must be familiar with proper clutch adjustment, linkage adjustment, lubrication and other maintenance troubleshooting procedures outlined in the Failure Analysis Guide.

 **Caution:** When disassembling various assemblies, lay all parts on a clean bench in the same sequence as removed to simplify and reduce the possibility of losing parts.

 **Caution:** Since the cost of a new part is generally a small fraction of the cost of downtime and labor, avoid reusing a questionable part that could lead to additional repairs and expense.

 **Caution:** Use of other than recommended tools, parts and instructions listed in this manual may place the safety of the service technician or vehicle driver in jeopardy.

The removal and installation procedure described for each component may vary for your vehicle.

 **Important:** For Self-Adjust and Heavy-Duty ECA clutches, it is required to install shipping bolts before removing the clutch assembly from the flywheel. For Standard Self-Adjust clutches, failure to do so may result in an over-adjusted clutch and will require a reset if reinstalling. For Heavy-Duty ECA clutches, failure to install shipping bolts will result in damage to the clutch assembly, and if reinstalled, will not function properly.

 **Important:** Do not tamper with the plastic tear drop insert in the top of the clutch cover. Tampering with this component may result in a non-warrantable failure.

 **Important:** For service information and assistance, call the Roadranger Help Desk at 1-800-826-HELP (4357) (Mexico: 01-800-826-HELP [4357]). You may also find more information about Eaton Clutches at www.Roadranger.com.

Every effort has been made to ensure the accuracy of the information contained in this manual. However, Eaton makes no warranty, expressed or implied, based on the information provided.

Advantage® Self-Adjusting Clutches

Special Instructions

None

Clutch Removal

Note: If the clutch is to be reinstalled and the transmission is still in vehicle, follow this procedure.

Warning: An assembled clutch weighs approximately 150 lb (68 kg). Avoid the risk of injury. Use proper equipment when lifting a clutch.

Caution: Note the position of the wear indicating tab on the clutch. If the tab is near the "REPLACE" position, the clutch should be replaced.

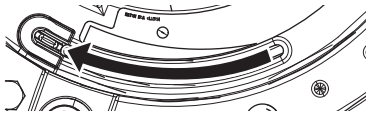

1. Insert appropriate clutch alignment tool.
2. Locate the four shipping bolts (7/16" x 14 x 1 3/4" UNC, hex head). Hand tighten them into the four cover holes, then turn one full turn.

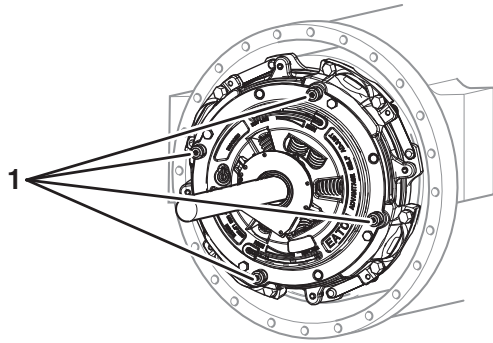

1. Shipping Bolts, (4) 7/16" x 14 x 1-3/4" UNC

3. Remove two of the top mounting bolts and install two 7/16" x 14 x 5" studs. Then remove the remaining six mounting bolts.

Special Tools

Appropriate Lifting Device (Clutch Jack)

Clutch Alignment Tool

4. Remove the clutch from the flywheel.

Note: Mark the proper position of the discs and intermediate plate (for re-installation).

Important: Do not tamper with the plastic tear drop insert in the top of the clutch cover. Tampering with this component may result in a non-warrantable failure.

Advantage® Self-Adjusting Clutches

Special Instructions

None

Special Tools

None

Clutch Installation

! **Important:** For machining of the flywheel friction surface, contact the OEM engine manufacture for specifications.

Measure Engine Flywheel Housing and Flywheel

! **Important:** The engine flywheel housing and flywheel must meet these specifications or it may result in premature clutch failure:

1. Remove and replace old pilot bearing per engine manufacturer instructions.
2. All gauge contact surfaces must be clean and dry. Clean flywheel surfaces of all grease, oil and rust preventatives. Failure to perform this function may affect the performance of the clutch.
3. Contact the OEM engine manufacturer for specific instructions for dial indication of the flywheel and flywheel housing.
4. Use a dial indicator to check the flywheel face runout:
 - a. Secure dial indicator base to flywheel housing face.
 - b. Put gauge finger in contact with flywheel face near the outer edge.
 - c. Rotate flywheel one revolution. Maximum runout is 0.008" (0.20 mm).

5. Use a dial indicator to check the pilot bearing bore runout.
 - a. Secure dial indicator base to flywheel housing face.
 - b. Position gauge finger so that it contacts pilot bearing bore.
 - c. Rotate flywheel one revolution. Maximum runout is 0.005" (0.13 mm).

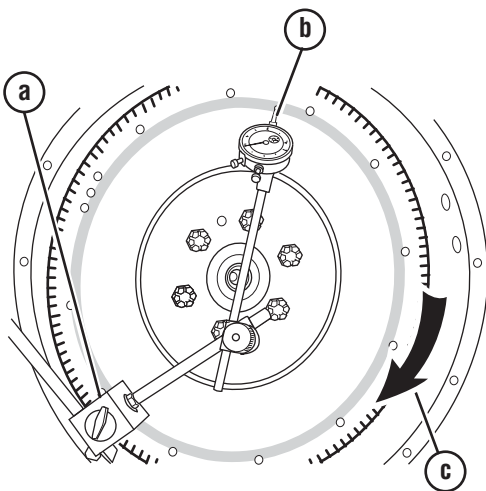
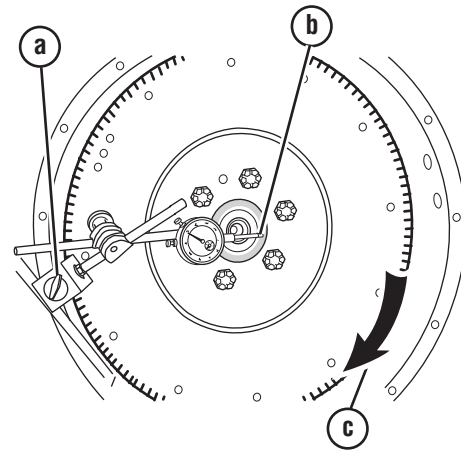

6. Use a dial indicator to check the flywheel housing I.D. runout.



- a. Secure dial indicator base to crankshaft.
- b. Put gauge finger against flywheel housing pilot I.D.
- c. Rotate flywheel one revolution. Maximum runout is 0.012" (0.30 mm).

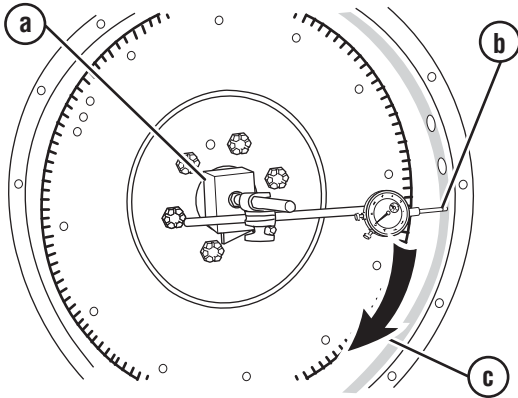

7. Use a dial indicator to check the flywheel housing face runout.

- a. Secure dial indicator base to flywheel near the outer edge.
- b. Put gauge finger against flywheel housing pilot.
- c. Rotate flywheel one revolution. Maximum runout is 0.008" (0.20 mm).

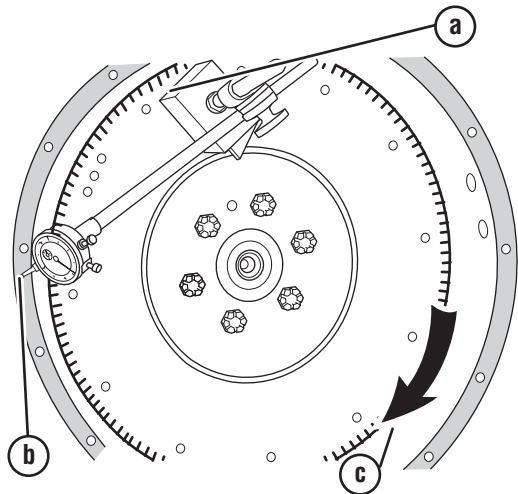

Clutch to Flywheel

Important: Use the Eaton Clutch Selector Guide (CLSL1511) to make sure you have the right clutch. Reference "Clutch Guide for Installation of Eaton Clutch Products" in the Appendix.

Note: When installing the clutch to the flywheel, position the wear indicator at the bottom of the flywheel to ease future clutch servicing.

1. Install pilot bearing.

Note: Mack 9-spring for Mack and Volvo engines 2007 and newer only.

2. Measure the flywheel bore. Use the Eaton Clutch Selector Guide to verify that the damper will fit into the flywheel bore.

Note: See the Appendix for a list of recommended pilot bearings.

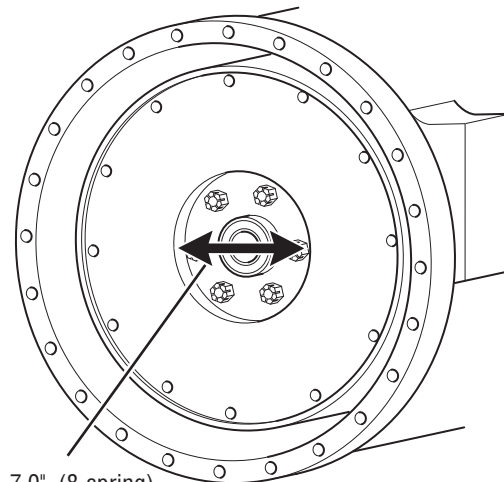

7.0" (8-spring)
8.5" (10-spring)
10.0" (7-spring and Mack 9-spring)

3. Insert aligning tool through bearing and rear driven disc.

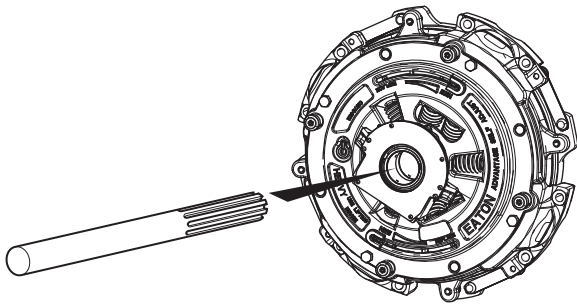

4. Install second disc onto aligning tool. Follow the orientation instructions on the disc.

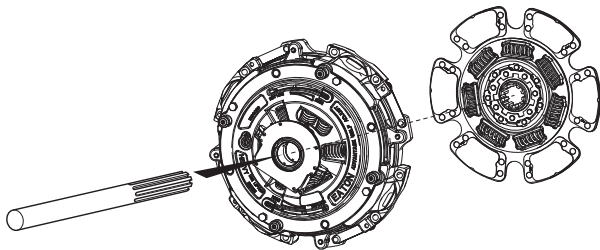

5. Install two 7/16" x 14 UNC x 5" studs into upper mounting holes. Install assembled clutch.

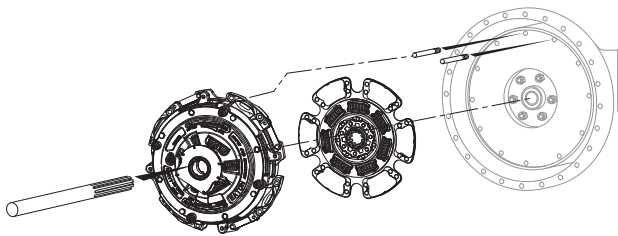

6. Install required lock washers and mounting bolts (7/16" x 14 UNC x 2-1/4" grade 5) finger tight. Replace studs with lock washers and bolts.

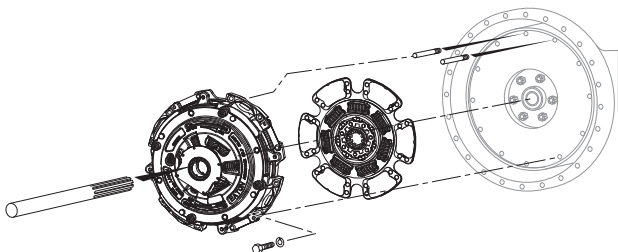

7. Progressively tighten mounting bolts in a crisscross pattern starting with the lower left bolt (1, 2, 3, 4, 5, 6, 7, 8). Torque to 40–50 lb-ft (54–68 N•m).

⚠ Caution: Failure to do this could result in improper piloting of the clutch to the flywheel and can result in a vibration, or worse, the clutch coming loose from the flywheel.

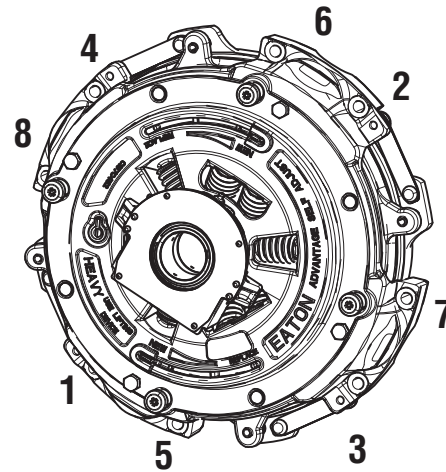

8. Remove four yellow shipping bolts in a crisscross pattern.

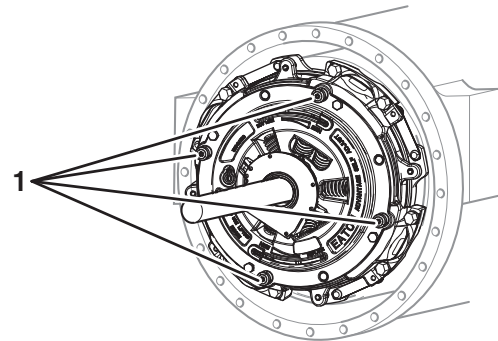

1. Yellow Shipping Bolts

9. Remove the aligning tool.

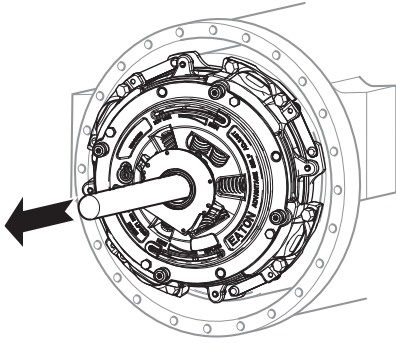

HD Advantage Self-Adjust Lube Hose Attachment

Note: The example shown is of a Lube Hose Attachment for a heavy-duty hydraulic release system.

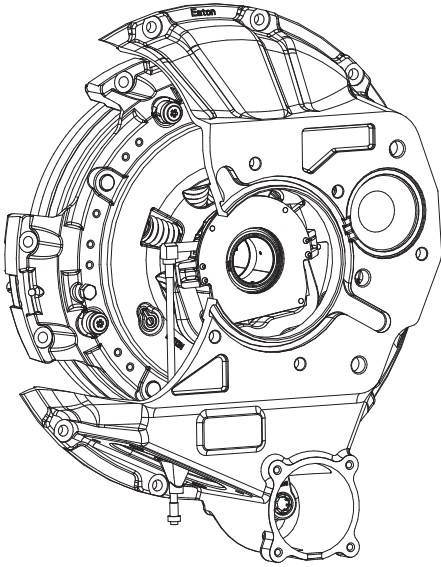

1. Install brass fitting into grease port on left side of release bearing housing using a Weatherhead socket. Hand tighten and continue to turn until the opening of the fitting is facing toward the 6 o'clock position.

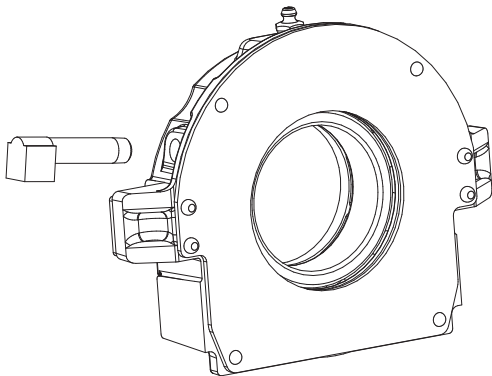

2. Install lube hose into brass fitting and tighten until hand tight, then turn an additional two turns while supporting the brass fitting.

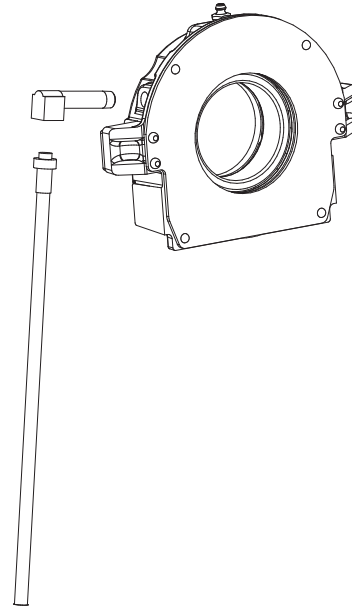

3. Lubricate release bearing until grease purges from release bearing housing. Use NLGI Grade 2 Lithium

4. complex grease With NLGI GC/LB certification.



Important: Eaton recommends the use of Roadranger EP2 for release bearing lubrication, or an equivalent Lithium Complex, NLGI #2 or #3 grease with a NLGI LB/GC performance rating and a dropping Point temperature of 220 C (428 F) or higher. Failure to use the proper grease may affect bearing life and void the warranty coverage on your Eaton product.

Note: A hand hole cover with grommet or plug is required with HD Advantage.

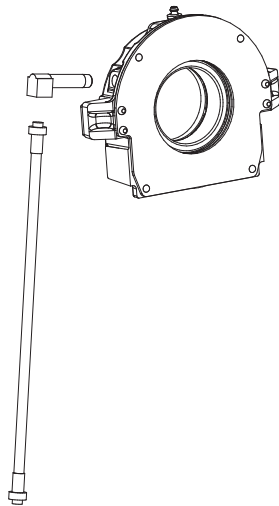

Transmission

Inspect Transmission for Wear

1. Replace any worn components.
2. Inspect the transmission bearing retainer cap. A worn/rough bearing retainer cap may cause the clutch brake to wear prematurely or affect proper clutch setup.
3. Inspect the cross shaft and bushings. Excessive wear at these points can cause side loading on the sleeve bushing, bushing failures and yoke bridge contact with the clutch when the pedal is down or affect proper clutch setup.

4. Inspect the shaft splines. Any wear on the splines will prevent the driven discs from sliding freely, causing poor clutch release (clutch drag). Slide discs full length of shaft to check for twisted shaft splines or affect proper clutch setup.



Important: Do not add lube (anti-seize or grease) to the input shaft splines. The discs must be free to move.

5. Inspect the input shaft spigot. Wear will not provide proper interface with the inner race of the pilot bearing. This can result in damage to the clutch or the pilot bearing.
6. Replace the clutch brake.
7. Measure the input shaft. Length should be 8.657" (219.89 mm) nominal, and not greater than 8.71" (221.23 mm). Ref. 1990 SAE handbook 4:36.106. Replace transmission bearing retainer cap if length is greater than 8.71" (219.89 mm).
8. Inspect the input shaft. Wear (roughness) can reduce sleeve bushing life and cause it to come out.
9. Inspect the release yoke. Worn fingers can cause bushing wear and yoke interference when the pedal is down or affect proper clutch setup.



Caution: Do not excessively force the transmission into the clutch assembly or engine housing. This will cause damage to the splines of the rear disc hub that is not warrantable. If the discs do not slide freely in the input shaft, investigate the cause of the problem and make any necessary changes. If the discs do not slide freely, the clutch will not release and the transmission will grind going into gear.



Caution: Do not let the transmission drop or hang unsupported in the driven discs. This can bend the discs, and the clutch will not release, causing damage that is not warrantable.



Caution: Do not use the cross shaft release lever (or a pipe over it) to pull the transmission into its final position. Pulling the bearing prior to the transmission being bolted to the engine flywheel housing will result in an over adjust of the clutch assembly. The release bearing gap to the clutch brake will be (less than 0.490") with this condition. Follow the In-Vehicle Resetting procedure on page 17.

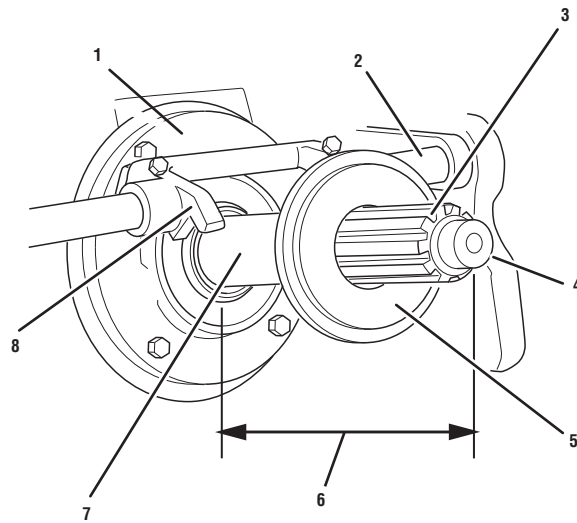

- 1. Transmission Bearing Cap
- 2. Cross Shaft and Bushings
- 3. Input Shaft Splines
- 4. Input Shaft Spigot

- 5. Clutch Brake
- 6. Measure Input Shaft
- 7. Input Shaft

Fasten Transmission to Flywheel Housing

⚠ Important: Before installing the transmission, be sure to plug or close all unused openings in the clutch housings.

1. Put transmission in gear. Make sure new clutch brake has been installed.

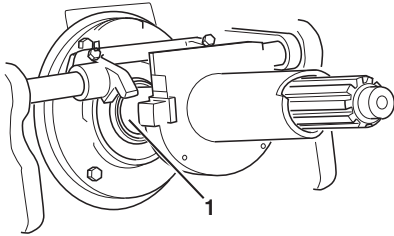

1. Clutch Brake

2. Make sure that the yoke fingers remain in the up position until they are over the release bearing housing.

⚠ Caution: Do not force transmission against clutch with yoke fingers in the up position. This will break the cast webbing of the clutch causing damage that is not warrantable.

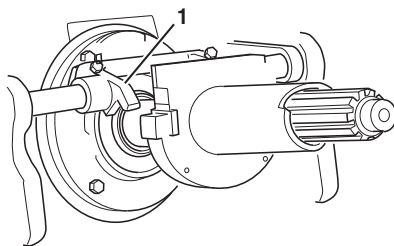

1. Yoke Fingers

3. Insert plug into hole in the upper left side of the clutch housing where the horizontal lube hose is utilized. (Image not shown.)

Note: If the lube hose assembly should need servicing, it can be replaced without removal of the transmission.

4. Position transmission so it is square to and aligned with engine.

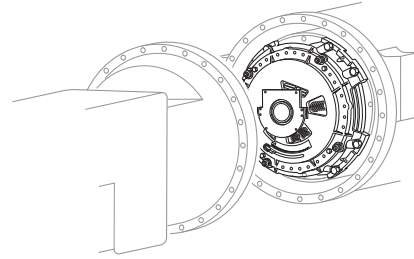

5. Mesh splines by moving transmission forward and rotating the output shaft.

⚠ Important: Do not add lube (anti-seize or grease) to the input shaft splines. The discs must be free to move.

⚠ Caution: Do not pull on release arm to install transmission. This will cause the clutch to overadjust.

⚠ Caution: Do not use excessive force. If it does not enter freely, investigate the cause of problem and make any necessary changes.

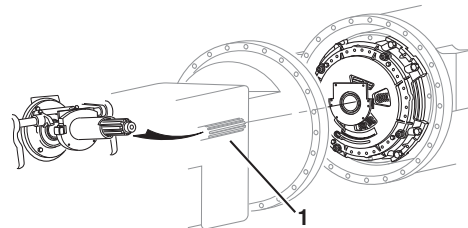

1. Output Shaft

6. Install mounting bolts and torque to OEM specs.

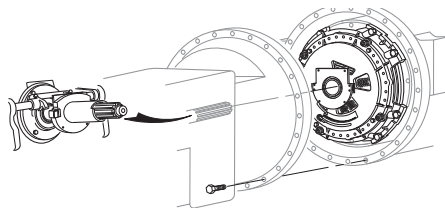

7. Install hand hold cover A-8173 with grommet positioned toward rear of hand hold opening in the clutch housing. Secure the hand hole cover with two 5/16" x 18 x 1/2" long bolts.

Advantage® Self-Adjusting Clutches

Special Instructions

None

Special Tools

None

Clutch Set-up

Adjust Clutch Linkage

⚠ Important: Inspect mechanical linkage for worn, loose or binding components. Inspect hydraulic linkage for leaks, contamination of fluid, damaged components and air in the system. Reference OEM service manuals for servicing of these components.

1. For mechanical linkages only, adjust the clutch linkage until the yoke fingers contact the release bearing (zero free-play in cab). For hydraulic linkages, go to Step 2.

2. Press the pedal to the floor up to five times. For mechanical linkages only, doing this gains free-play in the cab.

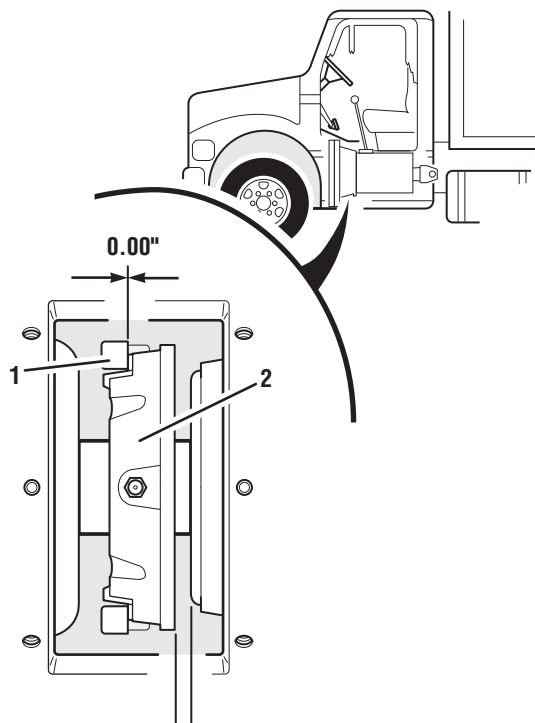

1. Yoke Finger
2. Release Bearing

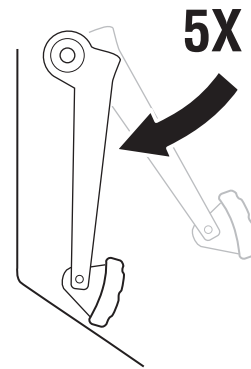

3. With the pedal up, measure the distance between the release bearing and the clutch brake. The correct distance should be 0.490"–0.560" (12.70–14.22 mm):



- If the distance is more than 0.560" (14.22 mm), return to Step 1 and readjust the clutch linkage. (For hydraulic linkages, verify that the linkage will stroke the bearing far enough for the initial adjustment to occur.)
- If the distance is less than 0.490" (12.70 mm), finish the install then see Advantage Heavy-Duty 15.5" Clutch Troubleshooting.

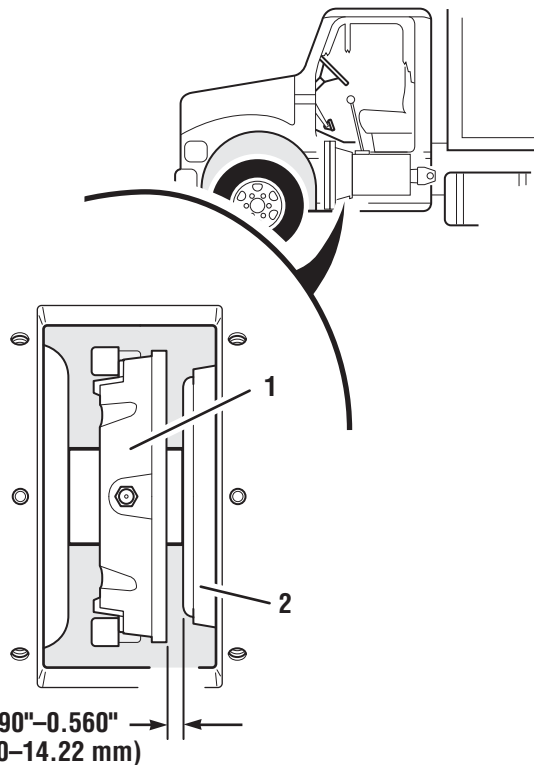

1. Release Bearing
2. Clutch Brake

4. Verify that the wear indicator has moved out of the new position.

Verify Clutch Brake Squeeze

Warning: Use a gauge long enough to keep hands away from moving parts.

1. Have an assistant insert 0.010" (0.25 mm) feeler gauge between the release bearing and the clutch brake. Press the pedal down to the floor:
 - For mechanical linkage, if the gauge does not clamp, readjust the truck linkage and move yoke fingers closer to the bearing.
 - For hydraulic linkage, skip this procedure and go to the "Lubricate" section on the next page.

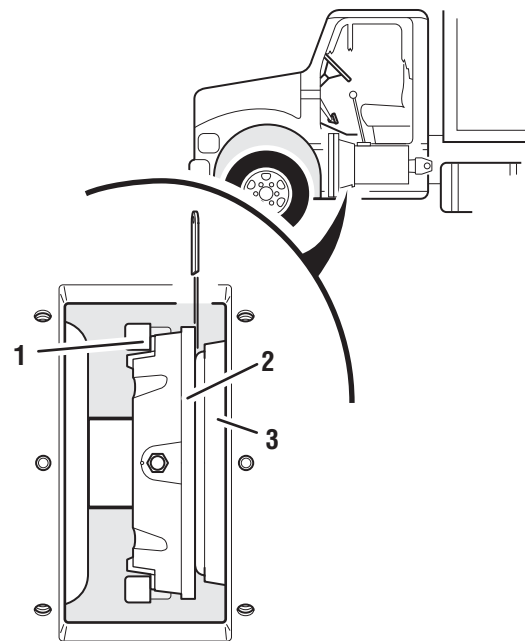

1. Yoke Finger
2. Release Bearing
3. Clutch Brake

2. For mechanical linkage only, slowly let up on the pedal and measure the pedal position at the moment the gauge can be removed:

- If pedal is more than 1" (25.4 mm) from the floor, readjust the truck linkage to move the yoke fingers further from the release bearing. Return to Step 1.

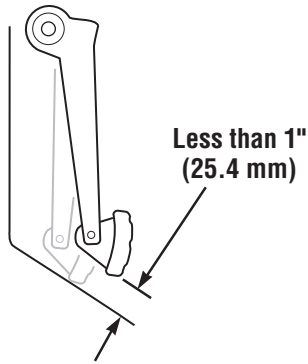

3. Verify for finger travel. For mechanical linkage only, measure gap at both sides of the release fork fingers. Gap should be 0.065" to 0.125". If not able to achieve this final adjustment, evaluate vehicle linkage system for worn, loose or improperly adjusted pedal stops.

⚠ Important: If release bearing travel is within specification of 0.490" to 0.560", do not reset the clutch.

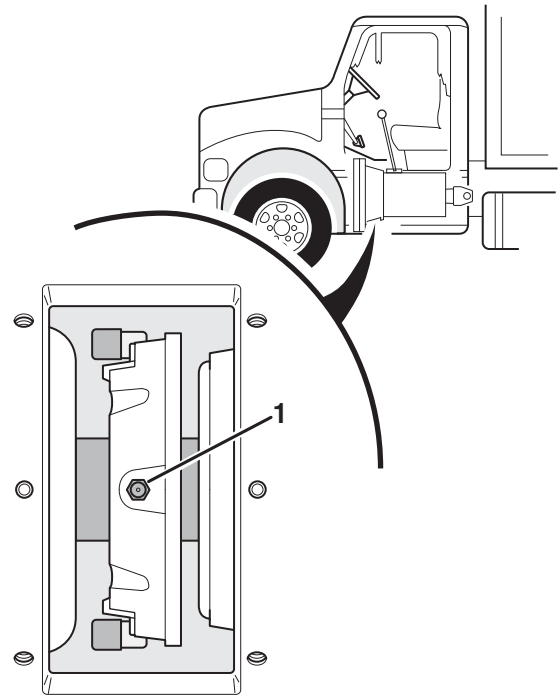

1. Release Bearing

Lubricate

Note: All clutches use a Lithium complex grease with a minimum of 325° F (163° C) operating range meeting NLGI Grade 2 or 3 specs. For additional lubrication information, see TCMT0021.

⚠ Caution: Failure to properly lubricate the bearing/bushing will result in bearing and sleeve failures. Using greases that are not compatible with the Eaton recommended grease can result in release bearing and bushing failures.

1. Release bearing lubrication: Apply grease through either the lube tube or a grease fitting, and continue to apply lube to cause enough grease to purge out of the release bearing housing onto the transmission input shaft. This will lube the clutch brake and bushing when the pedal is pressed.

2. Apply grease to yoke fingers.

3. Apply grease to the cross shaft bushings and linkage pivot points.

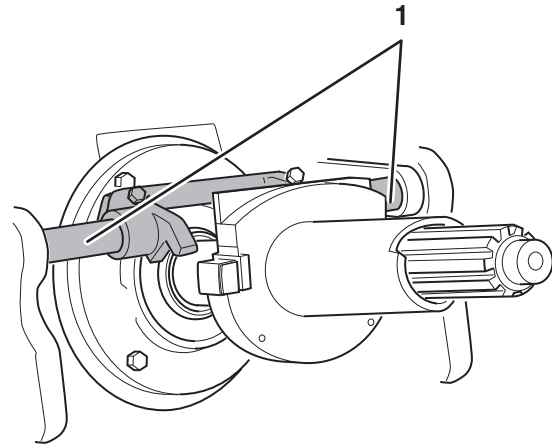
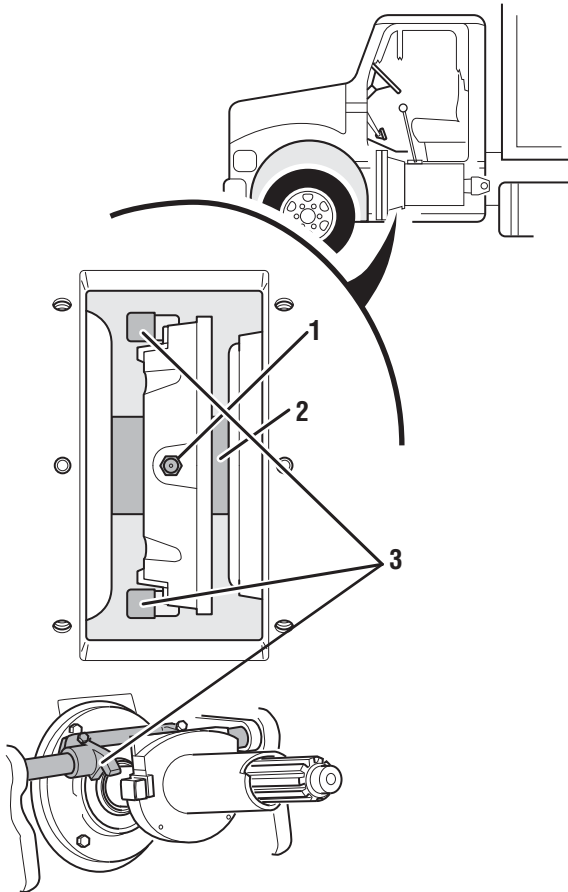

1. Cross Shaft Bushings and Linkage Pivot Points

- 1. Zerk
- 2. Input Shaft
- 3. Yoke Fingers

Advantage® Self-Adjusting Clutches

Special Instructions

None

Special Tools

None

Clutch Troubleshooting Procedures

Symptom-Driven Diagnostics

1. If the clutch is out of the vehicle, go to Out-of-Vehicle Resetting procedure. Based on your symptom, the following steps will direct you to the correct solution.
2. If the pedal travels too far before engaging the clutch or the clutch does not disengage, then there is too much free pedal.

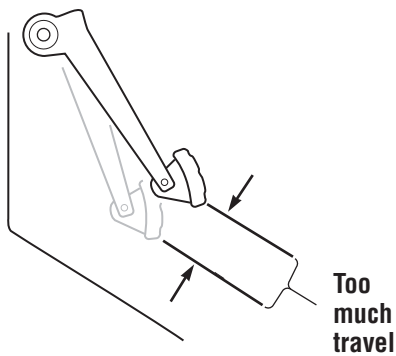

3. If the pedal travels too little before engaging the clutch, then there is too much free pedal.

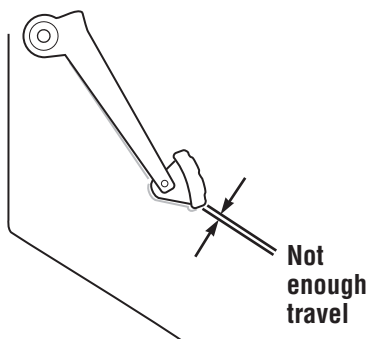

4. Not enough brake squeeze.

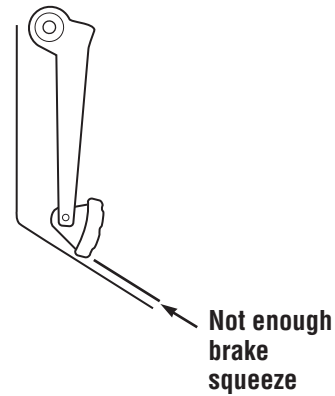

5. Not enough brake squeeze.

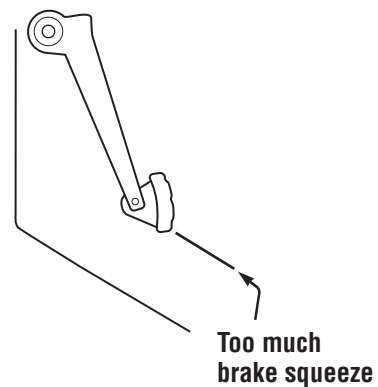

6. Measure distance between release bearing and clutch brake, then use the table on the next page to find the solution to the problem.

Note: Before measuring the distance between the release bearing and clutch brake, depress clutch pedal to remove free pedal in the cab. This will provide an accurate measurement for the gap between the release bearing and the clutch brake.

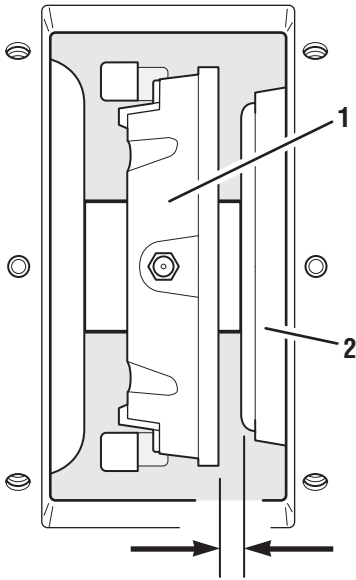

1. Release Bearing
2. Clutch Brake

Advantage® Self-Adjusting Clutches

Special Instructions

None

Special Tools

None

Clutch Resetting Procedures

In-Vehicle Resetting

1. Determine if the release bearing travel is correct. Measure the distance between the clutch brake and the release bearing with the clutch pedal up. If the measurement is between 0.490" and 0.590", the Self-Adjust clutch assembly has set itself correctly.
2. If the release bearing travel is less than 0.490", the Self-Adjust clutch must be reset. A common cause of this is the transmission was pulled in with the release arm during clutch installation.

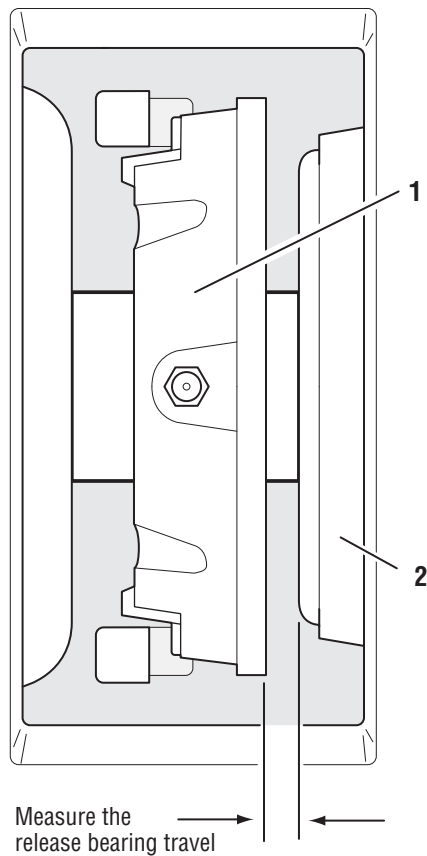

1. Release Bearing
2. Clutch Brake

3. Rotate the engine so that the cam tab can be reached through the transmission inspection opening.
4. Push the clutch pedal to the floor. While the clutch pedal is pushed to the floor, have someone push the cam tab to the new position using finger pressure. Once the cam tab is pushed to the new position, you can release the clutch pedal.

Note: If using a tool to assist with movement of the cam to the new position, use a blunt tool that will not damage the cam.

Note: If the cam tab does not move, there is not enough release bearing travel to allow the cams to separate. In this case, loosen the transmission and install 1/2" spacers between the flywheel housing and bell housing.

With the spacers in place, push the clutch pedal to the floor while someone pushes the cam tab to the new position. Once the tab is in the raised area at the new position, release the clutch pedal and remove the spacers. Torque the transmission mounting bolts.

Caution: Support the transmission with an appropriate jack or lifting device to prevent damage to the clutch cover and driven disc.

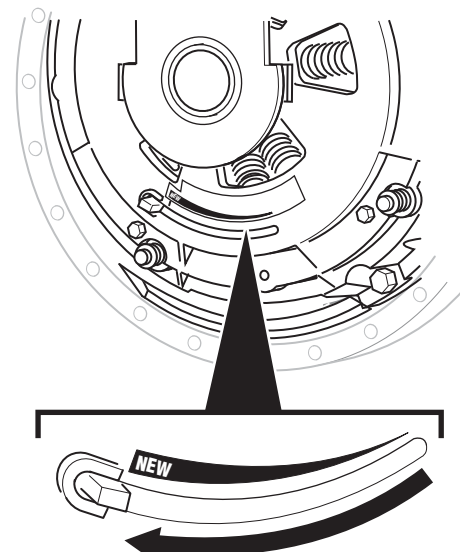

5. Install four shipping bolts and progressively tighten until they bottom out.

Caution: Only use hand tools to tighten shipping bolts. Do not use air tools.

Rotate the engine to access all four bolts:

- 15 1/2" Self-Adjust clutch uses 7/16 x 14 UNC x 1 3/4"
- Stamped 14" self-adjust uses 3/8 x 16 UNC x 1 1/4"

Note: This will reset the pressure plate separator pins and allow the clutch to release after installation.

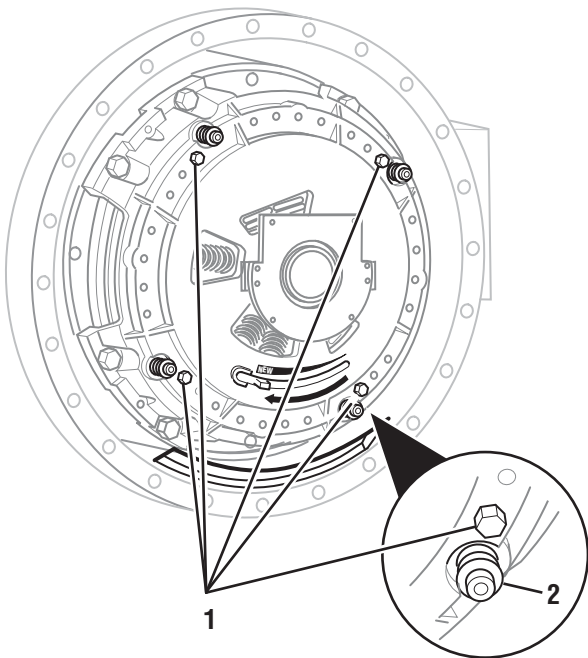

1. Shipping Bolts
2. Tamper-Proof Bolts

6. Remove the four shipping bolts. The release bearing and sleeve will move forward toward the engine when the bolts are removed. The clutch is now in the new position.

Note: If the procedure was performed correctly, the gap between the release bearing and the clutch brake should be about 0.750".

7. With the free pedal removed, push the clutch pedal down at least five times. Make sure the clutch release bearing contacts the clutch brake.

Note: For mechanical linkage, while engaging and releasing the clutch, the cab free pedal will increase. This indicates the clutch is adjusting to the environment.

Note: For hydraulic linkage, be sure to stroke the clutch pedal all the way to the floor, ensuring that the release bearing is being stroked far enough for the clutch to make an adjustment. With a hydraulic release system there will be no change in free pedal when the self-adjust clutch makes an adjustment.

8. Measure the distance between the clutch brake and the release bearing. It should be between 0.490" and 0.590".
9. If the release bearing travel is still greater than 0.590" between the clutch brake and the release bearing, repeat Steps 7 and 8.
10. For mechanical linkages, adjust the clutch linkage to achieve 1/8" clearance between the release yoke and the release bearing. Verify proper clutch brake squeeze.

Verify Clutch Brake Squeeze

Warning: Use a gauge long enough to keep hands away from moving parts.

1. Have an assistant insert 0.010" (0.25 mm) feeler gauge between the release bearing and the clutch brake. Press the pedal down to the floor to clamp the gauge:
 - If the gauge does not clamp, readjust the truck linkage and move the yoke finger closer to the bearing.

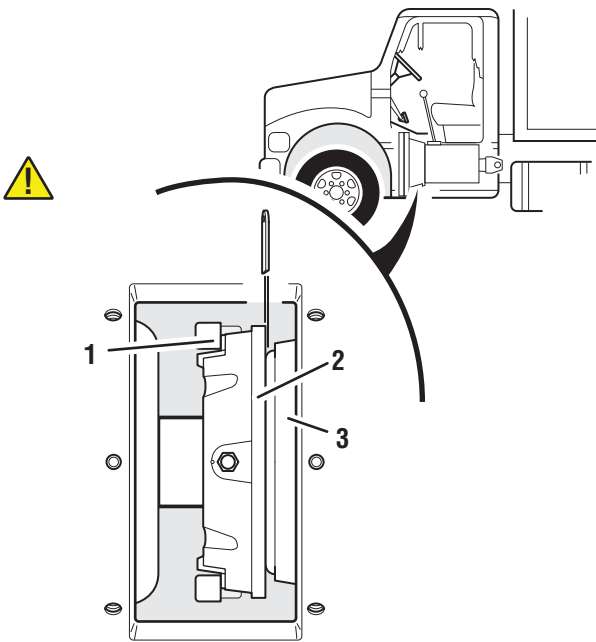

1. Yoke Finger
2. Release Bearing
3. Clutch Brake

2. Slowly let up on the pedal and measure the pedal position at the moment the gauge can be removed:
 - If pedal is more than 1" (25.4 mm) from the floor, readjust the truck linkage to move the yoke fingers further from the release bearing. Return to Step 1.

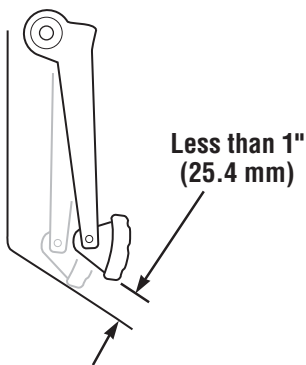

Out-of-Vehicle Reset Procedure for Heavy-Duty ECA or Advantage Self-Adjust Clutches (Using an Arbor Press)

1. Support the clutch in an arbor press with the bearing facing down.

⚠ Important: Make sure there is at least 1" of space to allow the bearing to move down and to provide access to the shipping bolts.

2. Center the ram and press downward on the retainer until it comes to a stop. Lock the ram in position.

Caution: Depressing the retainer too far may damage the cover assembly.

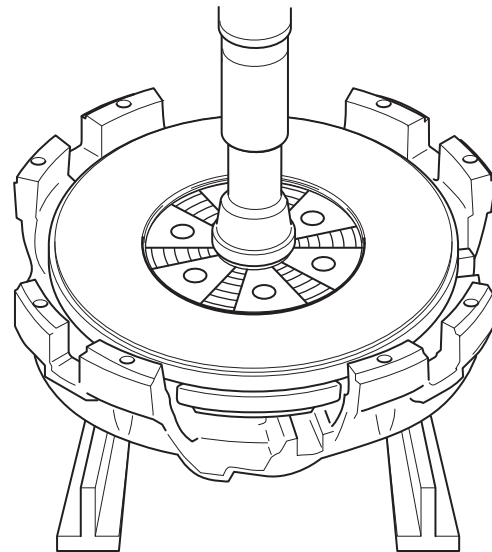

3. Remove the four shipping bolts if they have been installed.

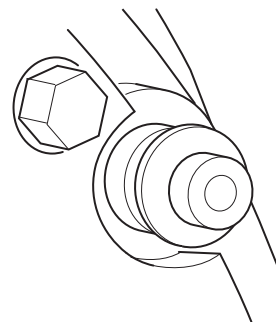

4. Slide the wear indicator tab to the “NEW” position and hold it in place with a magnet.

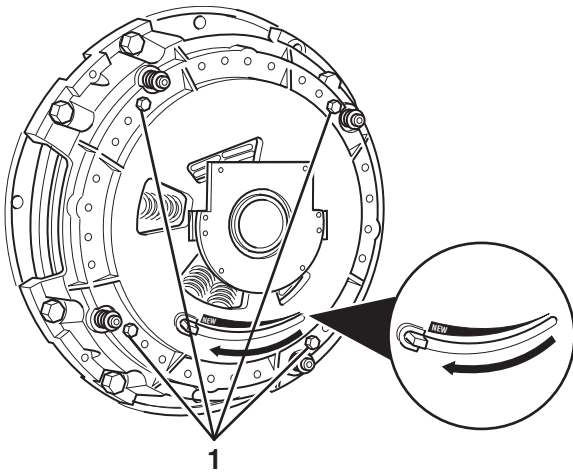

1. Shipping Bolts

5. Install the four shipping bolts (7/16" x 14 x 1-3/4" UNC, hex head). Progressively tighten (no air wrenches) the four shipping bolts (crisscross pattern) until the bolts are tight. Reference illustration for pressure plate position.

Note: This important step will reset the pressure plate separator pins and allow the clutch to release after re-installation.

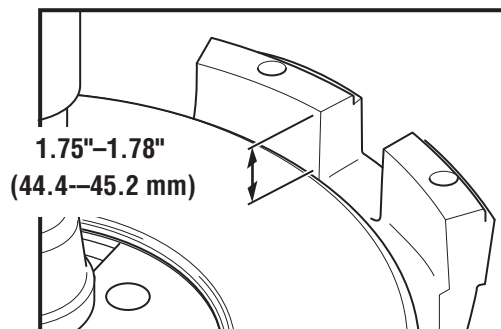

6. Reinstall the clutch using the original installation instructions.

Easy-Pedal Advantage® Manual Adjust Clutches

Special Instructions

None

Special Tools

None

Clutch Removal

Note: If clutch is to be reinstalled and transmission is still in vehicle, follow this procedure.

Warning: An assembled clutch weighs approximately 150 lb (68 kg). Avoid the risk of injury. Use proper equipment when lifting a clutch.

Caution: Note the position of the wear indicating tab on the clutch. If the tab is near the “REPLACE” position, the clutch should be replaced.

1. Insert appropriate clutch alignment tool.
2. Locate the four shipping bolts (7/16" x 14 x 1 3/4" UNC, hex head). Hand tighten them into the four cover holes, then turn one full turn.

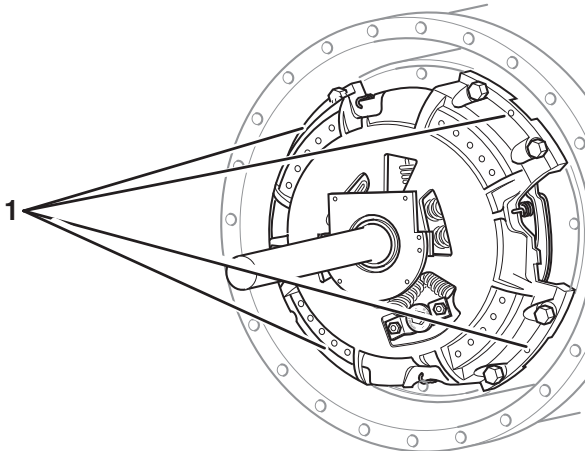

1. Shipping Bolts

3. Remove two of the top mounting bolts and install two 7/16" x 14 x 5" studs. Then remove the remaining six mounting bolts.
4. Remove the clutch from the flywheel.

Note: Mark the proper position of the discs and intermediate plate (for re-installation).

Easy-Pedal Advantage® Manual Adjust Clutches

Special Instructions

None

Special Tools

None

Clutch Installation

Important: For machining of the flywheel friction surface contact the OEM engine manufacture for specifications.

Measure Engine Flywheel Housing and Flywheel

Important: Engine flywheel housing and flywheel must meet these specifications or it may result in premature clutch failure.

1. Remove and replace old pilot bearing per engine manufacturer instructions.
2. All gauge contact surfaces must be clean and dry. Clean flywheel surfaces of all grease, oil and rust preventatives. Failure to perform this function can affect the performance of the clutch.
3. Contact OEM engine manufacture for specific instructions for dial indication of the flywheel and flywheel housing.
4. Use a dial indicator to check the flywheel face runout.
 - a. Secure dial indicator base to flywheel housing face.
 - b. Put gauge finger in contact with flywheel face near the outer edge.
 - c. Rotate flywheel one revolution. Maximum runout is 0.008" (0.20 mm).
5. Use a dial indicator to check the pilot bearing bore runout.
 - a. Secure dial indicator base to flywheel housing face.
 - b. Position gauge finger so that it contacts pilot bearing bore.
 - c. Rotate flywheel one revolution. Maximum runout is 0.005" (0.13 mm).

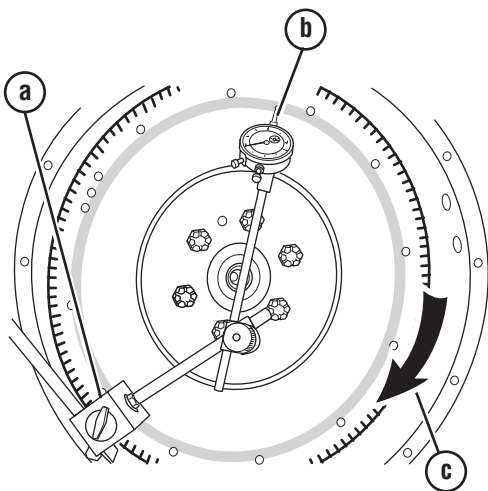
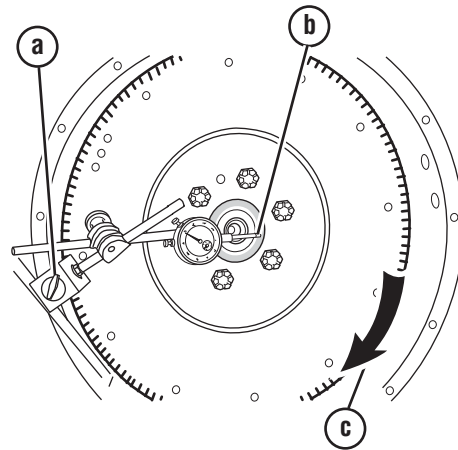

6. Use a dial indicator to check the flywheel housing I.D. runout.
 - a. Secure dial indicator base to crankshaft.
 - b. Put gauge finger against flywheel housing pilot I.D.
 - c. Rotate flywheel one revolution. Maximum runout is 0.012" (0.30 mm).

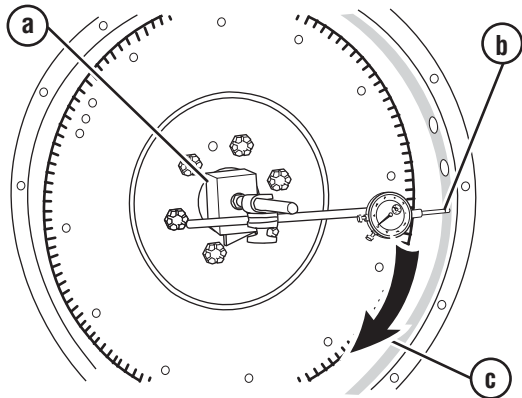

7. Use a dial indicator to check the flywheel housing face runout.
 - a. Secure dial indicator base to flywheel near the outer edge.
 - b. Put gauge finger against flywheel housing pilot.
 - c. Rotate flywheel one revolution. Maximum runout is 0.008" (0.20 mm).

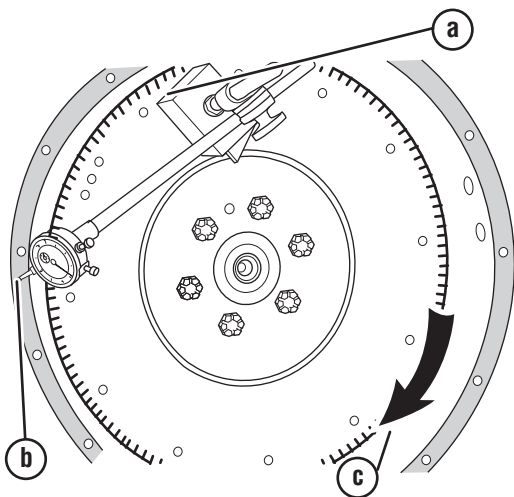

Easy-Pedal Advantage® Manual Adjust Clutches

Special Instructions

None

Special Tools

None

Install Clutch to Flywheel



Important: Use the Eaton Clutch Selector Guide (CLSL1511) to make sure you have the right clutch. Reference “Clutch Guide for Installation of Eaton Clutch Products” in the Appendix.

Note: When installing clutch to flywheel, position the adjuster at the bottom of flywheel to ease future clutch servicing.

1. Install pilot bearing. Measure the flywheel bore. Use the Eaton Clutch Selector Guide (CLSL1511) to verify that the damper will fit into the flywheel bore.

Note: See the Appendix for a list of recommended pilot bearings.

Note: Mack 9-spring for Mack and Volvo engines 2007 and newer only.

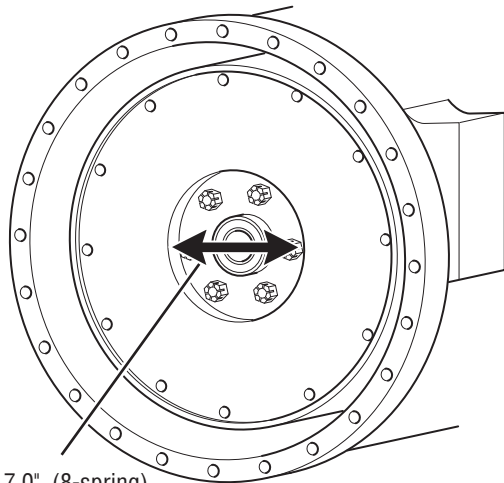

7.0" (8-spring)
8.5" (10-spring)
10.0" (7-spring and Mack 9-spring)

2. Insert aligning tool through bearing.

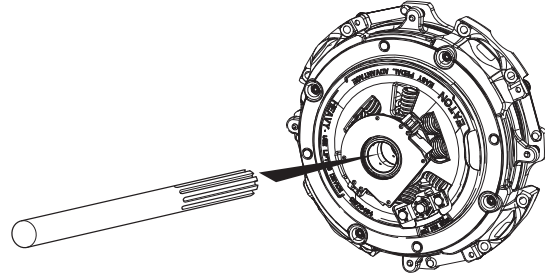

3. Install second disc onto aligning tool. Follow the orientation instructions on the disc.

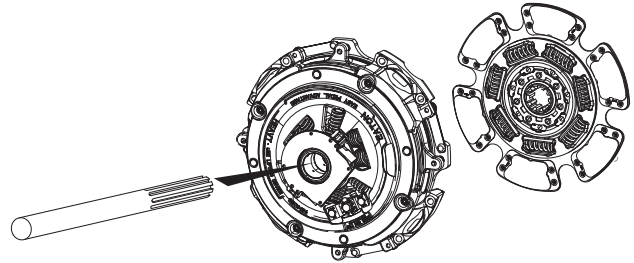

4. Install two 7/16" x 14 UNC x 5" studs into upper mounting holes. Install assembled clutch.

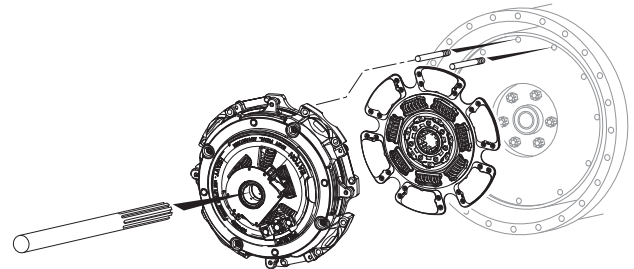

5. Install required lock washers and mounting bolts (7/16" x 14 UNC x 2-1/4" grade 5) finger tight. Replace studs with lock washers and bolts.

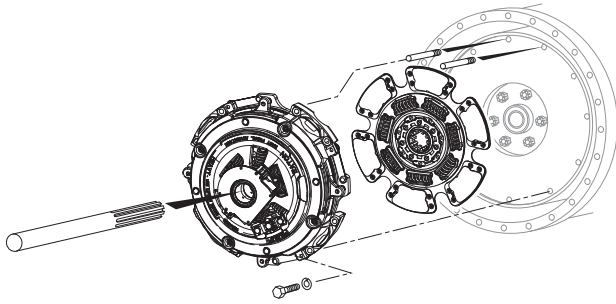

6. Progressively tighten mounting bolts in a crisscross pattern starting with the lower left bolt (1, 2, 3, 4, 5, 6, 7, 8). Torque to 40–50 lb-ft (54–68 N•m).

⚠ Caution: Failure to do this could result in improper piloting of the clutch to the flywheel and can result in a vibration, or worse, the clutch coming loose from the flywheel.

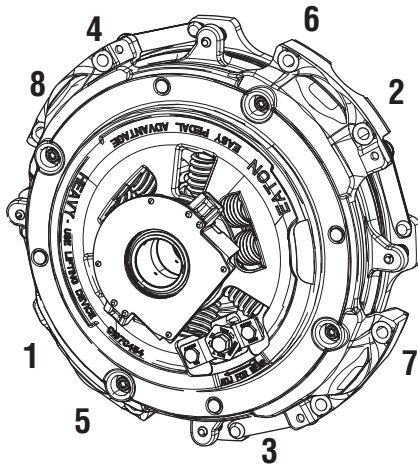

7. Verify bearing position is 3/8"–5/8" (9.5–15.9 mm) from cover.

Note: If this dimension is out of specification, contact the Roadranger Call Center.

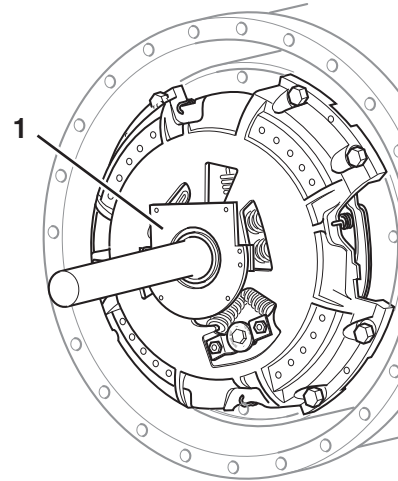

1. Bearing Position

8. Remove the aligning tool. Be sure shipping blocks are removed.

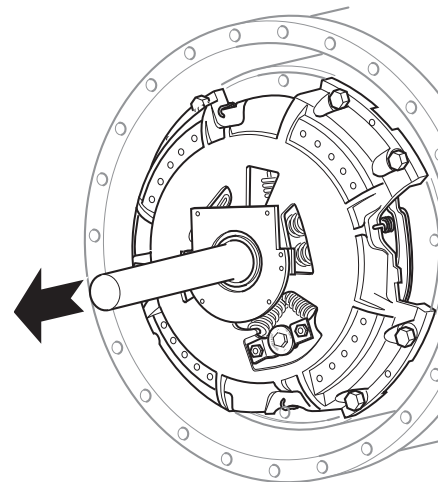

Transmission

Inspect Transmission for Wear

1. Replace any worn components.

2. Inspect the transmission bearing retainer cap. A worn/rough bearing retainer cap may cause the clutch brake to wear prematurely or affect proper clutch setup.
3. Inspect the cross shaft and bushings. Excessive wear at these points can cause side loading on the sleeve bushing, bushing failures and yoke bridge contact with the clutch when the pedal is down or affect proper clutch setup.
4. Inspect the shaft splines. Any wear on the splines will prevent the driven discs from sliding freely, causing poor clutch release (clutch drag). Slide discs full length of shaft to check for twisted shaft splines or affect proper clutch setup.

⚠ Important: Do not add lube (anti-seize or grease) to the input shaft splines. The discs must be free to move.

5. Inspect the input shaft spigot. Wear will not provide proper interface with the inner race of the pilot bearing. This can result in damage to the clutch or the pilot bearing.
6. Replace the clutch brake.

7. Measure the input shaft. Length should be 8.657" (219.89 mm) nominal, and not greater than 8.71" (221.23 mm). Ref. 1990 SAE handbook 4:36.106. Replace transmission bearing retainer cap if length is greater than 8.71" (219.89 mm).
8. Inspect the input shaft. Wear (roughness) can reduce sleeve bushing life and cause it to come out.
9. Inspect the release yoke. Worn fingers can cause bushing wear and yoke interference when the pedal is down or affect proper clutch setup.

⚠ Caution: Do not let the transmission drop or hang unsupported in the driven discs. This can bend the discs, and the clutch will not release, causing damage that is not warrantable.

⚠ Caution: Do not excessively force the transmission into the clutch assembly or engine housing. This will cause damage to the splines of the rear disc hub that is not warrantable. If the discs do not slide freely in the input shaft, investigate the cause of the problem and make any necessary changes. If the discs do not slide freely, the clutch will not release and the transmission will grind going into gear.

Note: For most common vehicle linkages, the lube hose can be attached at the lower grease zerk location. For other linkage system, reference OEM instructions for lube hose attachment and routing.

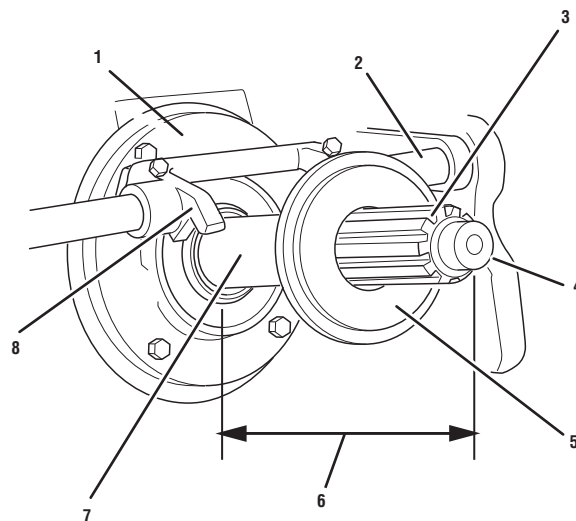

1. Transmission Bearing Cap
2. Cross Shaft and Bushings
3. Input Shaft Splines
4. Input Shaft Spigot

5. Clutch Brake
6. Measure Input Shaft
7. Input Shaft

Fasten Transmission to Flywheel Housing

Transmission installation and clutch set-up procedures are the same for the 14" and 15.5" clutch.

1. Put transmission in gear. Be sure new clutch brake has been installed.

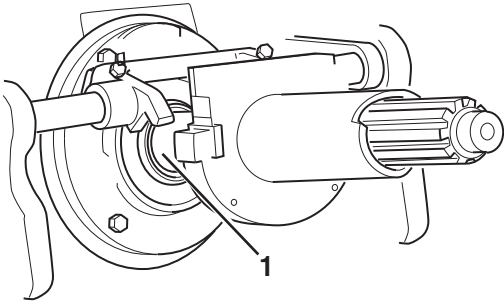

1. Clutch Brake

2. Make sure that the yoke fingers remain in the up position until they are over the release bearing housing.

Caution: Do not force transmission against clutch with yoke fingers in the up position. This will break the cast webbing of the clutch causing damage that is not warrantable.

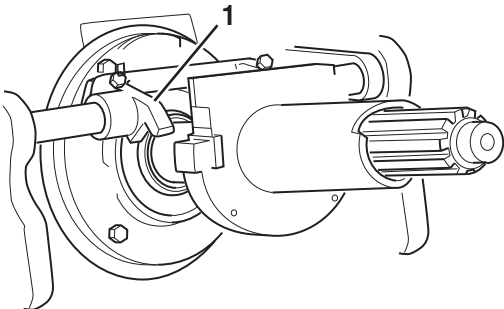

1. Yoke Fingers

3. Position transmission so it is square to and aligned with engine.

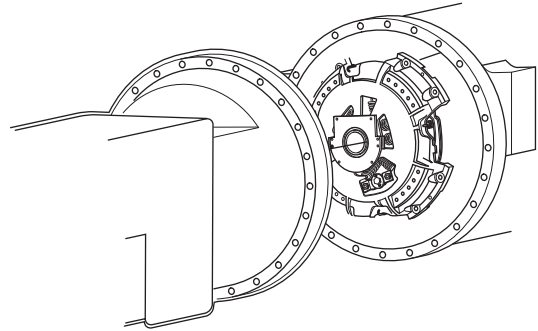

4. Mesh splines by moving transmission forward and rotating the output shaft. Do not use excessive force. Do not let the transmission hang unsupported in the discs.

Warning: Do not let the transmission drop or hang unsupported in the driven discs. This can cause the discs to become distorted and the clutch to not release.

Important: Do not add lube (ant-seize or grease) to the input shaft splines. The discs must be free to slide.

Caution: Do not use excessive force. If it does not enter freely, investigate the cause of problem and make any necessary changes.

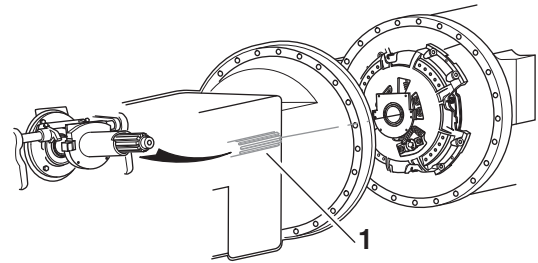

1. Output Shaft

5. Install mounting bolts and torque to OEM specs.

Note: Eaton does not recommend the use of manual adjusted clutches with hydraulic linkages. (Reference OEM information for hydraulic linkage.)

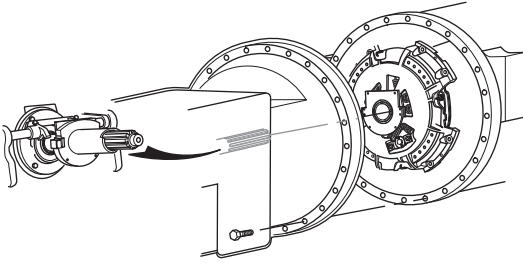

Easy-Pedal Advantage® Manual Adjust Clutches

Special Instructions

None

Special Tools

None

Clutch Set-up

Adjust Bearing Position

Note: Before measuring the distance between the release bearing and clutch brake depress clutch pedal to remove free pedal in the cab.

1. Measure the distance between the release bearing and the clutch brake:
 - If the distance is correct, 0.500"–0.560" (12.70–14.22 mm), then Verify Clutch Brake Squeeze, go to Step 4.
 - If the distance is not between 0.500"–0.560" (12.70–14.22 mm), go to Step 2.

2. Have an assistant hold down clutch pedal so internal adjustment can be made.

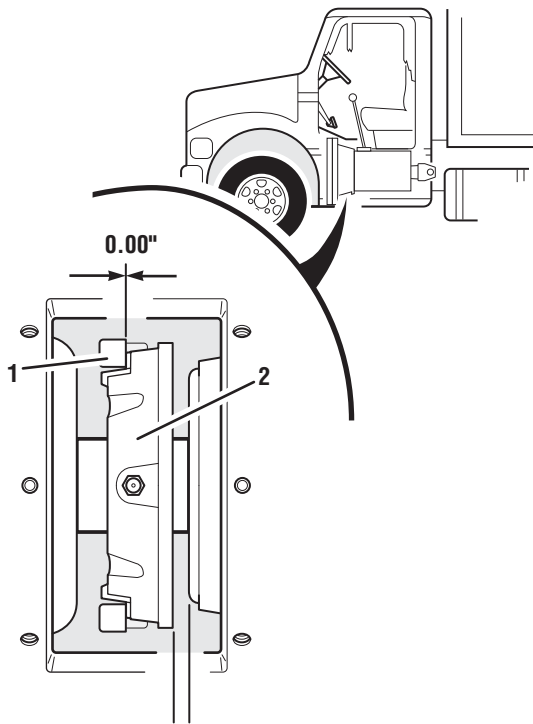
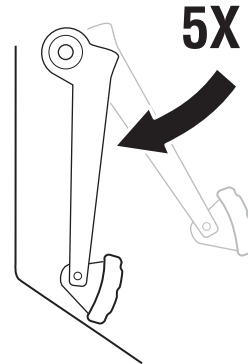

1. Yoke Finger
2. Release Bearing

3. Adjust bearing position (clutch needs to be released so that the adjusting ring can be turned to change the gap between the release bearing and the clutch brake).
4. For the Easy-Pedal and Easy-Pedal Advantage only, while pedal is held down, push adjusting nut and turn (as viewed facing the engine):
 - If measurement was more than 0.560" (14.22 mm), turn adjusting nut clockwise.
 - If measurement was less than 0.500" (12.77 mm), turn adjusting nut counterclockwise.

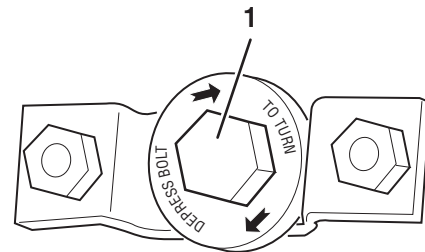

1. Adjusting Nut Part Number 125489

5. For the Value Clutch only, while pedal is held down, remove lockstrap and move adjusting lug:
- If measurement was more than 0.560" (14.22 mm), move adjusting lug to the left (shown).
 - If measurement was less than 0.500" (12.77 mm), move adjusting lug to the right.

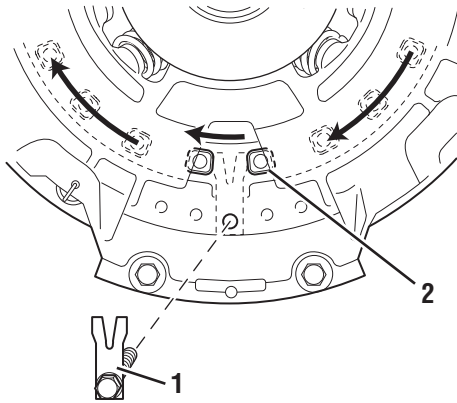

1. Lockstrap
2. Adjusting Lug

Verify Free-Play (Mechanical Linkage Only)

1. Measure the distance between yoke tips and bearing wear pads simultaneously. This distance should be 1/8" (3.2 mm). If distance is not 1/8" (3.2 mm), see Step 2.



Important: Do not change bearing position.

Note: 1/8" (3.2 mm) distance will create free-play in cab. Free-play in cab may be different on different truck makes, models and years.

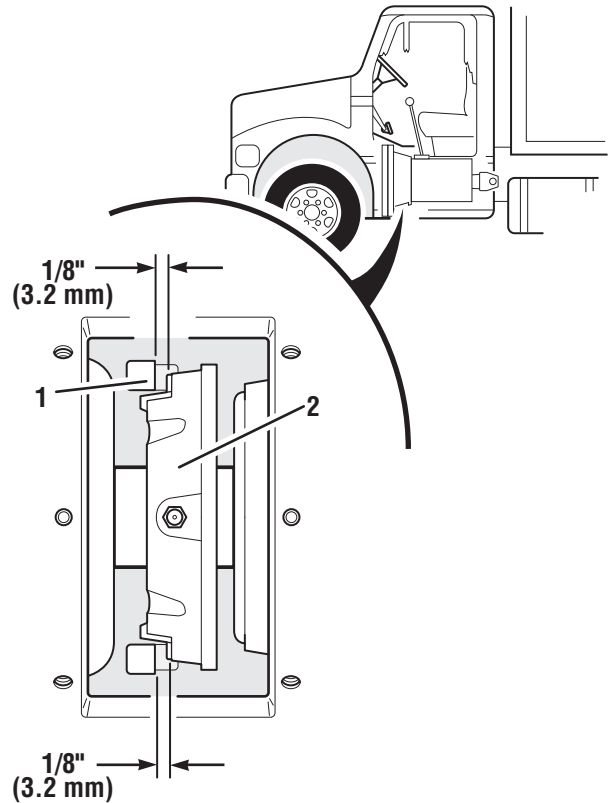

1. Yoke Finger
2. Release Bearing

- The truck linkage should allow for a minimum of 0.685" of yoke finger movement; 0.125" for free-play, 0.500" for the bearing and 0.060" for clutch brake squeeze. If it is necessary to increase the free-play, adjust upper pedal stop to raise or lower the pedal in the cab. If this is not possible, check the OEM parts manual to verify the correct clutch arm was installed at the factory.

⚠ Important: Do not change free-play by changing the bearing position. Correct bearing position is 0.500"–0.560" (12.70–14.22 mm).

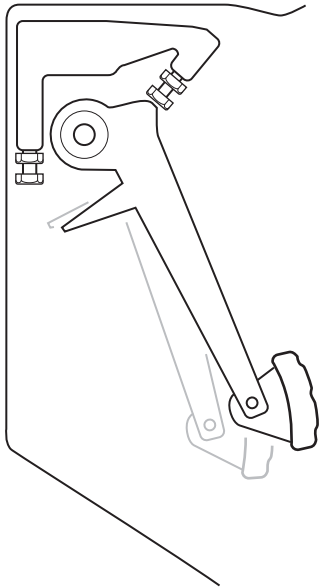

lower the pedal in the cab. If this is not possible, check the OEM parts manual to verify the correct clutch arm was installed at the factory. For hydraulic linkage, skip this procedure and go to the "Lubricate" section on the next page.

⚠ Important: Do not change free-play by changing the bearing position. Correct bearing position is 0.500"–0.560" (12.70–14.22 mm).

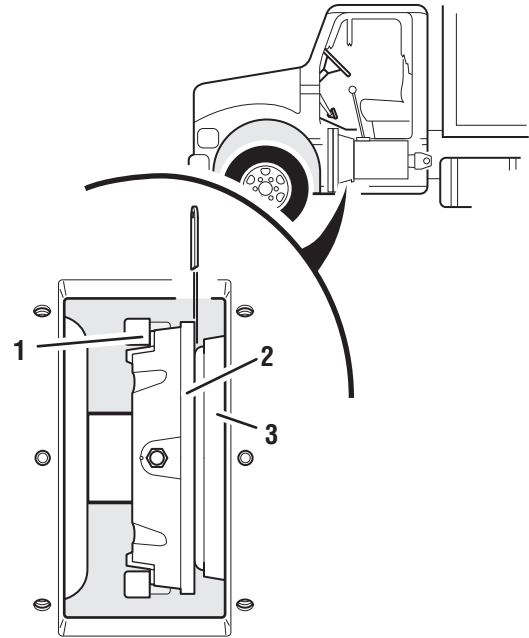

Verify Clutch Brake Squeeze

⚠ Warning: Use a gauge long enough to keep hands away from moving parts.

- Have an assistant insert 0.010" (0.25 mm) feeler gauge between the release bearing and the clutch brake. Press the pedal down to the floor to clamp the gauge:
 - The truck linkage should allow for a minimum of 0.685" of yoke finger movement: 0.125" for free-play, 0.500" for the bearing and 0.060" for clutch brake squeeze. If it is necessary to increase the free-play, adjust the upper pedal stop to raise or

- Yoke Finger
- Release Bearing
- Clutch Brake

2. Slowly let up on the pedal and measure the pedal position at the moment the feeler gauge can be removed:
 - Clutch brake engagement should be approximately 1" from end of pedal stroke.

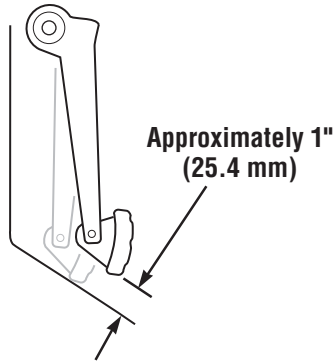

Lubricate

Note: All clutches use a Lithium complex grease with a minimum of 325° F (163° C) operating range meeting NLGI Grade 2 or 3 specs.

Note: Apply ample grease that is visibly exiting the opening and contacts the transmission shaft. This will lube the clutch brake and bushing when the pedal is pressed. For additional lubrication information, see TCMT0021



Caution: Failure to properly lubricate the bearing/bushing will result in bearing and sleeve failures.

3. Apply grease to yoke fingers.

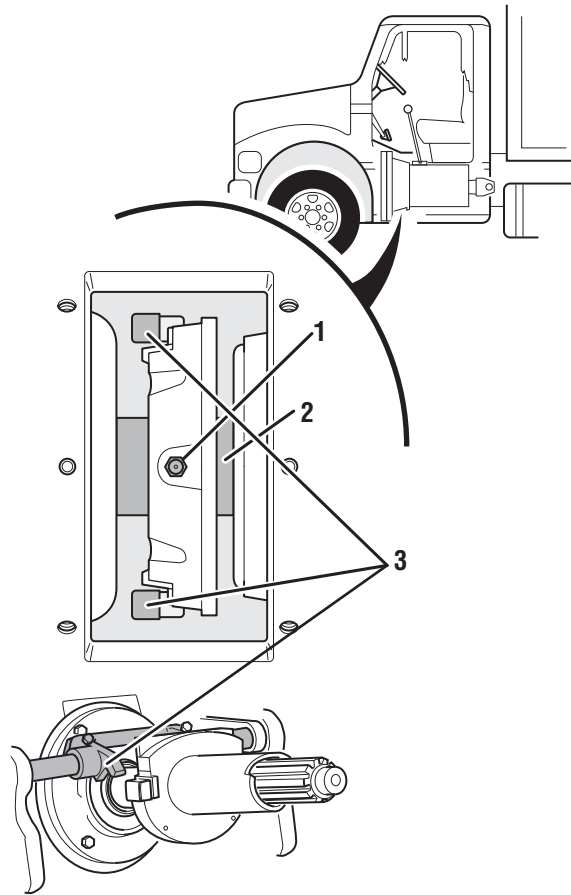

1. Zerk
2. Input Shaft
3. Yoke Fingers

4. Apply grease to the cross shaft bushings and linkage pivot points.

 **Important:** Do not add lube (anti-seize or grease) to the input shaft splines. The disc must be free to move.

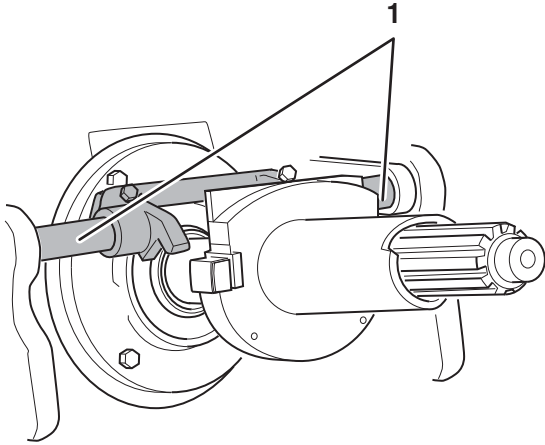

1. Cross Shaft Bushings and Linkage Pivot Points

14" Cast Clutches

Special Instructions

None

Special Tools

None

Clutch Set-up

14" Clutch to Flywheel

Note: For the intermediate plate drive pin removal, refer to OEM for style of drive pins and locking mechanisms.

1. Ensure the correct flywheel depth is 2-15/16".
2. Put front disc into flywheel. Flywheel side must be toward engine. Use new slots to put intermediate plate on pins.
3. Install six 3/8" x 16 x 1/4" set screws. Then install second group of set screws to lock the lower set screw (typical set up). Verify with OEM if drive pin set up is different.
4. Install new pilot bearing. Reference the Appendix for list of recommended pilot bearings.
5. Install two 3/8" x 2-1/2" studs into upper mounting holes.

6. Install disc into flywheel. Follow the orientation instructions on the disc.

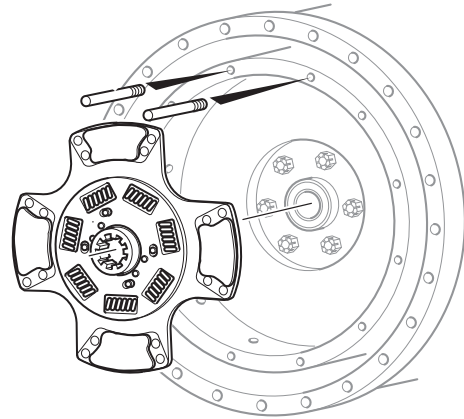

7. Install intermediate plate onto drive pins.

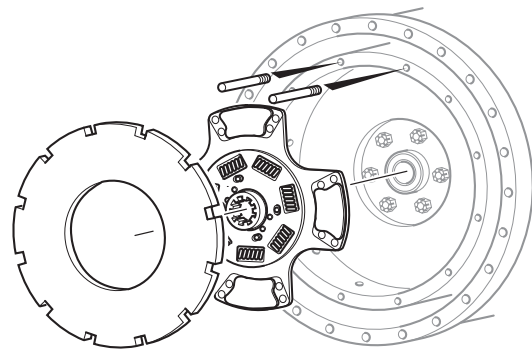
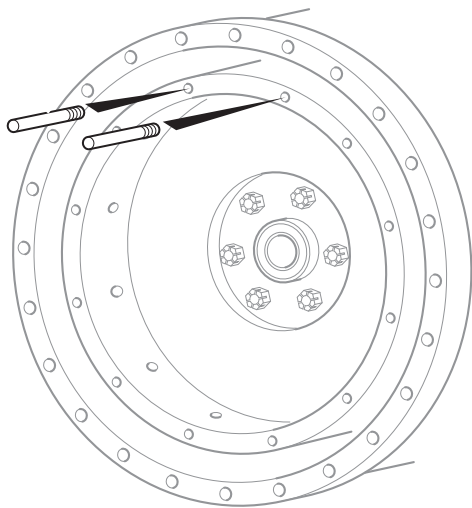

8. For the Super-Duty Clutch only, install three equally spaced anti-rattle springs.

Note: Check orientation on anti-rattle springs before installing.

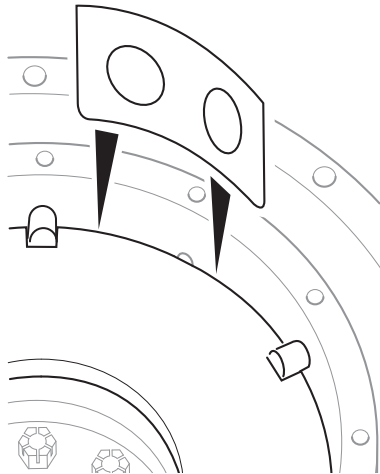

9. For the Super-Duty Clutch only, reinstall flywheel to engine referencing engine manufactures torque and run out specifications.
10. Install second disc onto flywheel. Follow the orientation instructions on the disc.

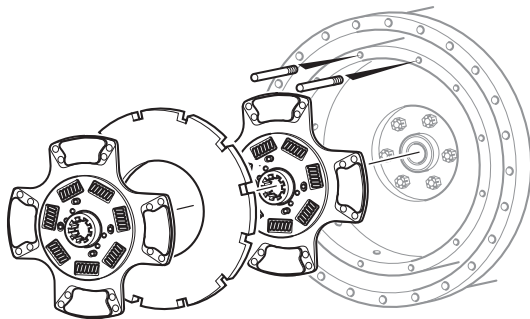

11. Insert aligning tool through discs. Be sure that the stub end of the alignment tool is inserted into the pilot bearing.

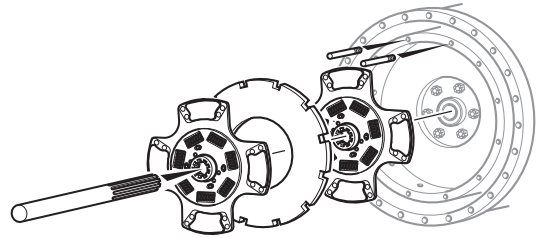

12. Slide cover over aligning tool.

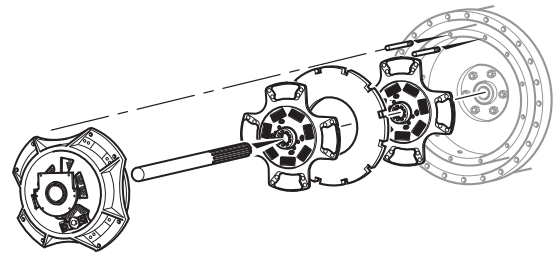

13. Install lock washers and mounting bolts (3/8" x 16 x 1-1/4" grade 5) finger tight. Replace studs with lock washers and bolts.

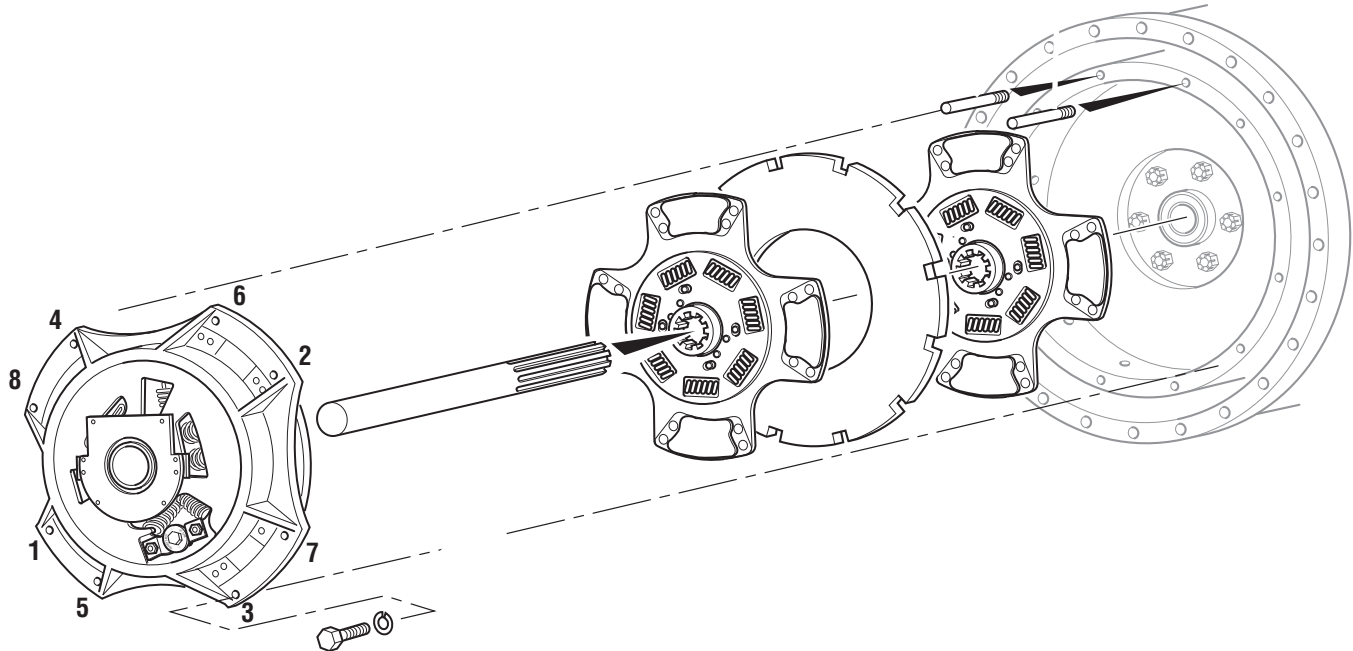

14. Progressively tighten mounting bolts in a crisscross pattern starting with the lower left bolt (1, 2, 3, 4, 5, 6, 7, 8). Torque to 25–35 lb-ft (34–47 N•m).

⚠ Caution: Failure to do this could result in improper piloting of the clutch to the flywheel and can result in a vibration or worse the clutch coming loose from the flywheel.

15. Remove the aligning tool. Be sure shipping blocks are removed.

Transmission

Inspect Transmission for Wear

1. Replace any worn components.
2. Inspect the transmission bearing retainer cap. A worn/rough bearing retainer cap may cause the clutch brake to wear prematurely or affect proper clutch setup.
3. Inspect the cross shaft and bushings. Excessive wear at these points can cause side loading on the sleeve bushing, bushing failures and yoke bridge contact with the clutch when the pedal is down or affect proper clutch setup.

4. Inspect the shaft splines. Any wear on the splines will prevent the driven discs from sliding freely, causing poor clutch release (clutch drag). Slide discs full length of shaft to check for twisted shaft splines or affect proper clutch setup.

Important: Do not add lube (anti-seize or grease) to the input shaft splines. The discs must be free to move.

5. Inspect the input shaft spigot. Wear will not provide proper interface with the inner race of the pilot bearing. This can result in damage to the clutch or the pilot bearing.
6. Replace the clutch brake.

7. Measure the input shaft. Length should be 8.657" (219.89 mm) nominal, and not greater than 8.71" (221.23 mm). Ref. 1990 SAE handbook 4:36.106. Replace transmission bearing retainer cap if length is greater than 8.71" (219.89 mm).
8. Inspect the input shaft. Wear (roughness) can reduce sleeve bushing life and cause it to come out.

9. Inspect the release yoke. Worn fingers can cause bushing wear and yoke interference when the pedal is down or affect proper clutch setup.



Caution: Do not let the transmission drop or hang unsupported in the driven discs. This can bend the discs, and the clutch will not release, causing damage that is not warrantable.



Caution: Do not excessively force the transmission into the clutch assembly or engine housing. This will cause damage to the splines of the rear disc hub that is not warrantable. If the discs do not slide freely in the input shaft, investigate the cause of the problem and make any necessary changes. If the discs do not slide freely, the clutch will not release and the transmission will grind going into gear.

Note: For most common vehicle linkages, the lube hose can be attached at the lower grease zerk location. For other linkage system, reference OEM instructions for lube hose attachment and routing.

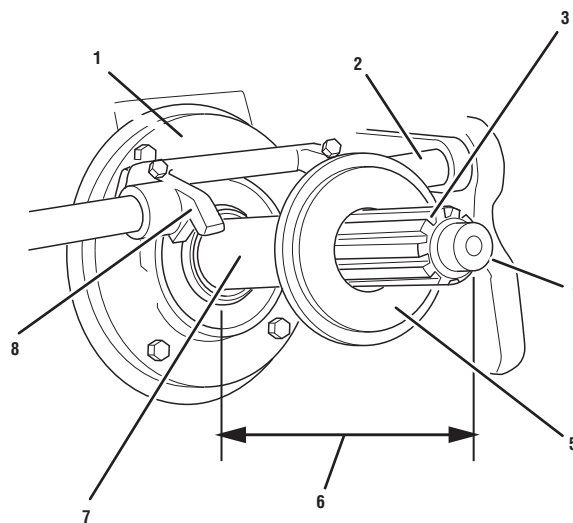

1. Transmission Bearing Cap
2. Cross Shaft and Bushings
3. Input Shaft Splines
4. Input Shaft Spigot

5. Clutch Brake
6. Measure Input Shaft
7. Input Shaft

Fasten Transmission to Flywheel Housing

Transmission installation and clutch set-up procedures are the same for the 14" and 15.5" clutch.

1. Put transmission in gear. Be sure new clutch brake has been installed.

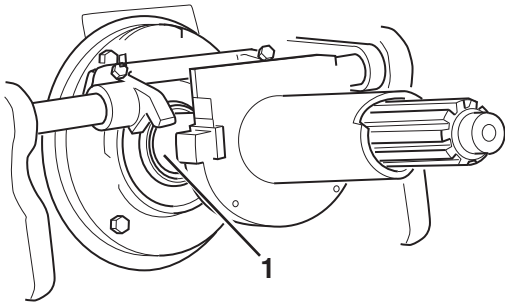

1. Clutch Brake

2. Make sure that the yoke fingers remain in the up position until they are over the release bearing housing.

⚠ Caution: Do not force transmission against clutch with yoke fingers in the up position. This will break the cast webbing of the clutch causing damage that is not warrantable.

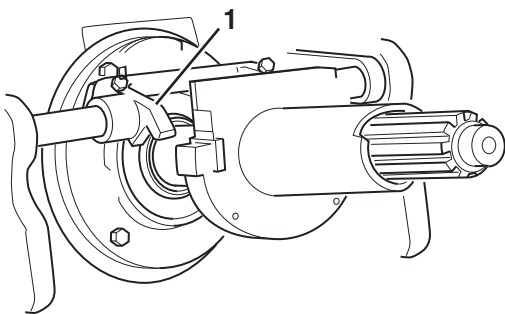

1. Yoke Fingers

3. Position transmission so it is square to and aligned with engine.

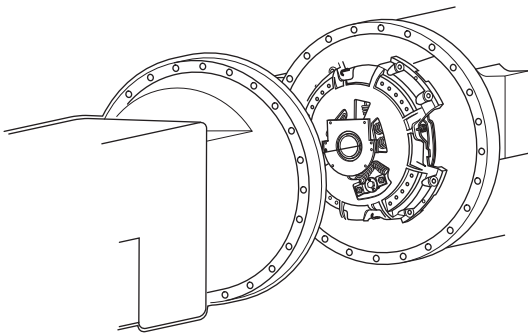

4. Mesh splines by moving transmission forward and rotating the output shaft. Do not use excessive force. Do not let the transmission hang unsupported in the discs.

⚠ Warning: Do not let the transmission drop or hang unsupported in the driven discs. This can cause the discs to become distorted and the clutch to not release.

⚠ Important: Do not add lube (ant-seize or grease) to the input shaft splines. The discs must be free to slide.

⚠ Caution: Do not use excessive force. If it does not enter freely, investigate the cause of problem and make any necessary changes.

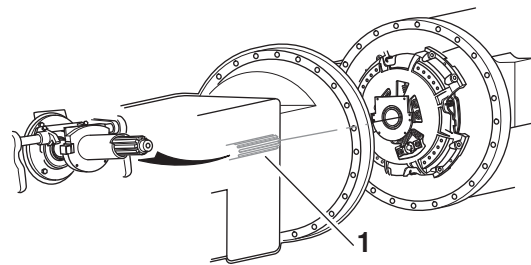

1. Output Shaft

5. Install mounting bolts and torque to OEM specs.

Note: Eaton does not recommend the use of manual adjusted clutches with hydraulic linkages. (Reference OEM information for hydraulic linkage.)

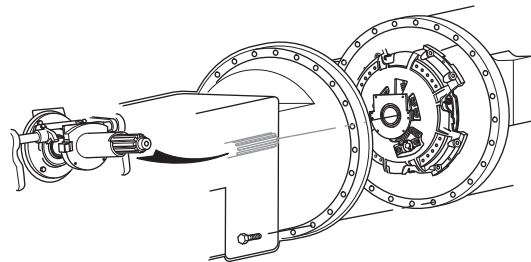

Evertough®, Value Clutch, Reman Self-Adjust Clutches

Special Instructions

None

Special Tools

Appropriate Lifting Device (Clutch Jack)

Clutch Alignment Tool

Clutch Removal

Note: If the clutch is to be reinstalled and the transmission is still in vehicle, follow this procedure.

Warning: An assembled clutch weighs approximately 150 lb (68 kg). Avoid the risk of injury. Use proper equipment when lifting a clutch.

Caution: Note the position of the wear indicating tab on the clutch. If the tab is near the “REPLACE” position, the clutch should be replaced.



1. Insert appropriate clutch alignment tool.
2. Locate the four shipping bolts (7/16" x 14 x 1 3/4" UNC, hex head). Hand tighten them into the four cover holes, then turn one full turn.

3. Remove two of the top mounting bolts and install two 7/16" x 14 x 5" studs. Then remove the remaining six mounting bolts.

4. Remove the clutch from the flywheel.

Note: Mark the proper position of the discs and intermediate plate (for re-installation).

Important: Do not tamper with the plastic tear drop insert in the top of the clutch cover. Tampering with this component may result in a non-warrantable failure.

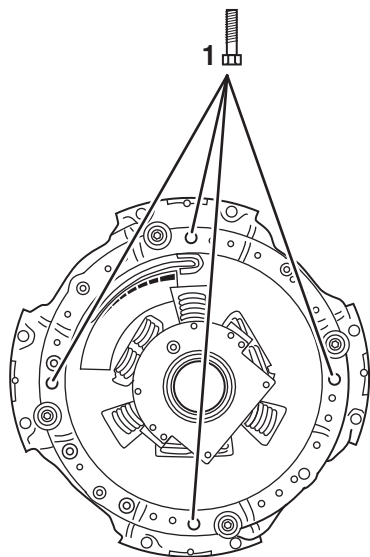

1. Shipping Bolts, (4) 7/16" x 14 x 1-3/4" UNC

Evertough®, Value Clutch, Reman Self-Adjust Clutches

Special Instructions

None

Special Tools

None

Clutch Installation

! **Important:** For machining of the flywheel friction surface, contact the OEM engine manufacture for specifications.

Measure Engine Flywheel Housing and Flywheel

! **Important:** The engine flywheel housing and flywheel must meet these specifications or it may result in premature clutch failure:

1. Remove and replace old pilot bearing per engine manufacturer instructions.
2. All gauge contact surfaces must be clean and dry. Clean flywheel surfaces of all grease, oil and rust preventatives. Failure to perform this function may affect the performance of the clutch.
3. Contact the OEM engine manufacturer for specific instructions for dial indication of the flywheel and flywheel housing.
4. Use a dial indicator to check the flywheel face runout:
 - a. Secure dial indicator base to flywheel housing face.
 - b. Put gauge finger in contact with flywheel face near the outer edge.
 - c. Rotate flywheel one revolution. Maximum runout is 0.008" (0.20 mm).
5. Use a dial indicator to check the pilot bearing bore runout.
 - a. Secure dial indicator base to flywheel housing face.
 - b. Position gauge finger so that it contacts pilot bearing bore.
 - c. Rotate flywheel one revolution. Maximum runout is 0.005" (0.13 mm).

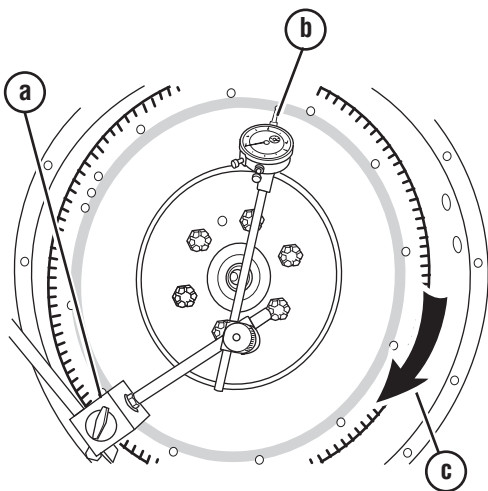
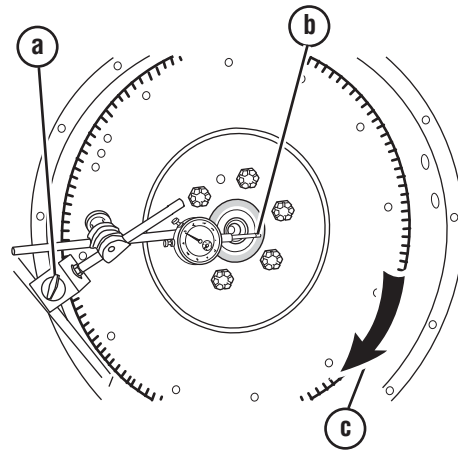

6. Use a dial indicator to check the flywheel housing I.D. runout.



- a. Secure dial indicator base to crankshaft.
- b. Put gauge finger against flywheel housing pilot I.D.
- c. Rotate flywheel one revolution. Maximum runout is 0.012" (0.30 mm).

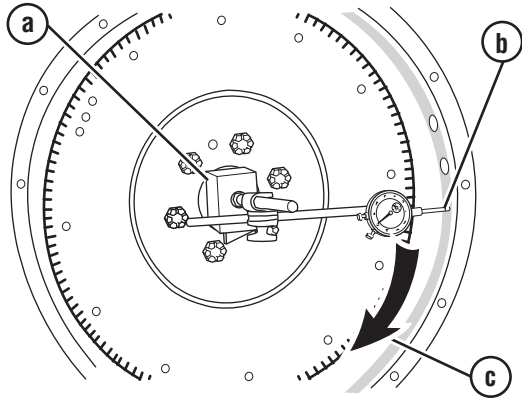

7. Use a dial indicator to check the flywheel housing face runout.

- a. Secure dial indicator base to flywheel near the outer edge.
- b. Put gauge finger against flywheel housing pilot.
- c. Rotate flywheel one revolution. Maximum runout is 0.008" (0.20 mm).

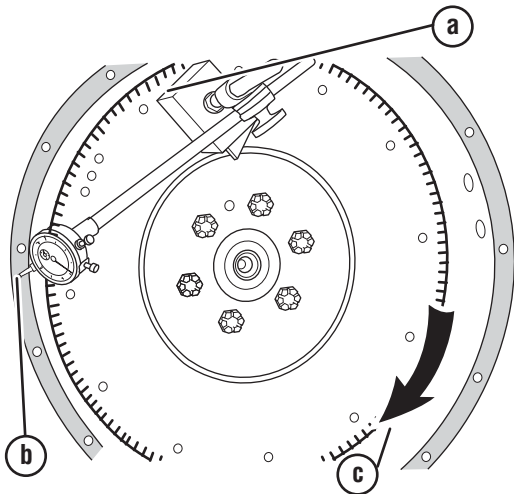

Clutch to Flywheel

Important: Use the Eaton Clutch Selector Guide (CLSL1511) to make sure you have the right clutch. Reference “Clutch Guide for Installation of Eaton Clutch Products” in the Appendix.

Note: When installing the clutch to the flywheel, position the wear indicator at the bottom of the flywheel to ease future clutch servicing.

1. Install pilot bearing.

Note: Mack 9-spring for Mack and Volvo engines 2007 and newer only.

2. Measure the flywheel bore. Use the Eaton Clutch Selector Guide to verify that the damper will fit into the flywheel bore.

Note: See the Appendix for a list of recommended pilot bearings.

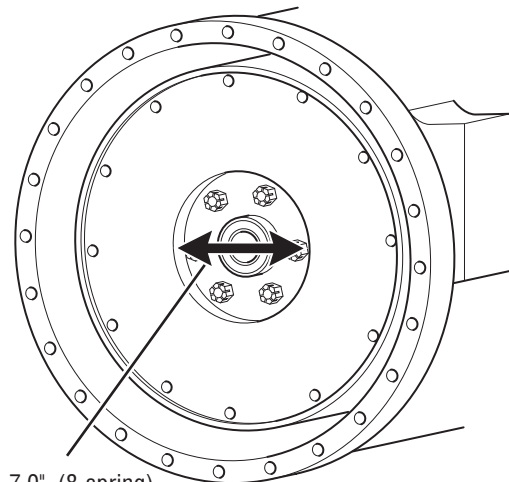

7.0" (8-spring)
 8.5" (10-spring)
 10.0" (7-spring and Mack 9-spring)

3. Insert the aligning tool through the bearing.

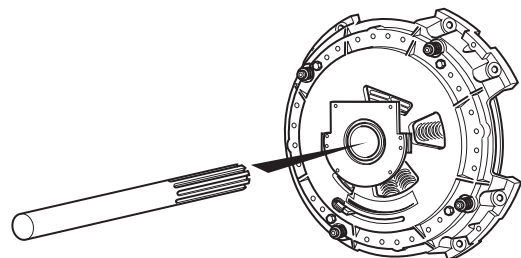

4. Install the disc onto the aligning tool. Follow the orientation instructions on the disc.

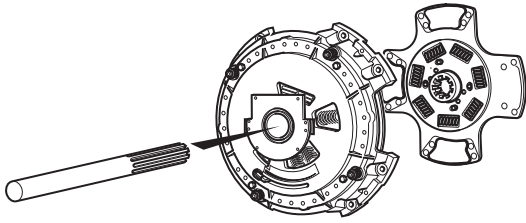

5. Install the intermediate plate into the slots on the clutch cover. Flywheel side must face the flywheel.

Note: Separator pins need to be positioned flush on the side of the intermediate plate facing the cover assembly.

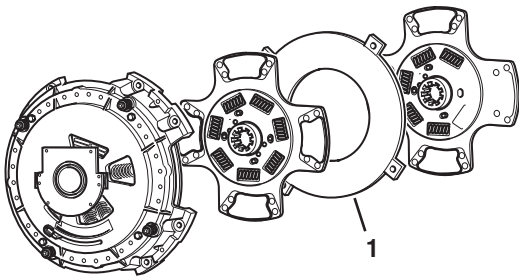

1. Transmission Bearing Cap

6. Install second disc onto aligning tool. Follow the orientation instructions on the disc.

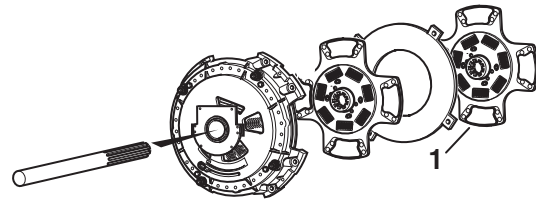

1. Second Wheel

7. Install two 7/16" x 14 UNC x 5" studs into upper mounting holes. Install assembled clutch.

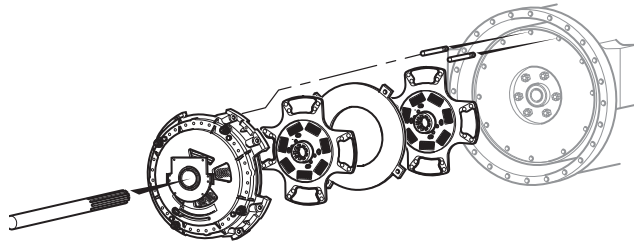

8. Install required lock washers and mounting bolts (7/16" x 14 UNC x 2-1/4" grade 5) finger tight. Replace studs with lock washers and bolts.

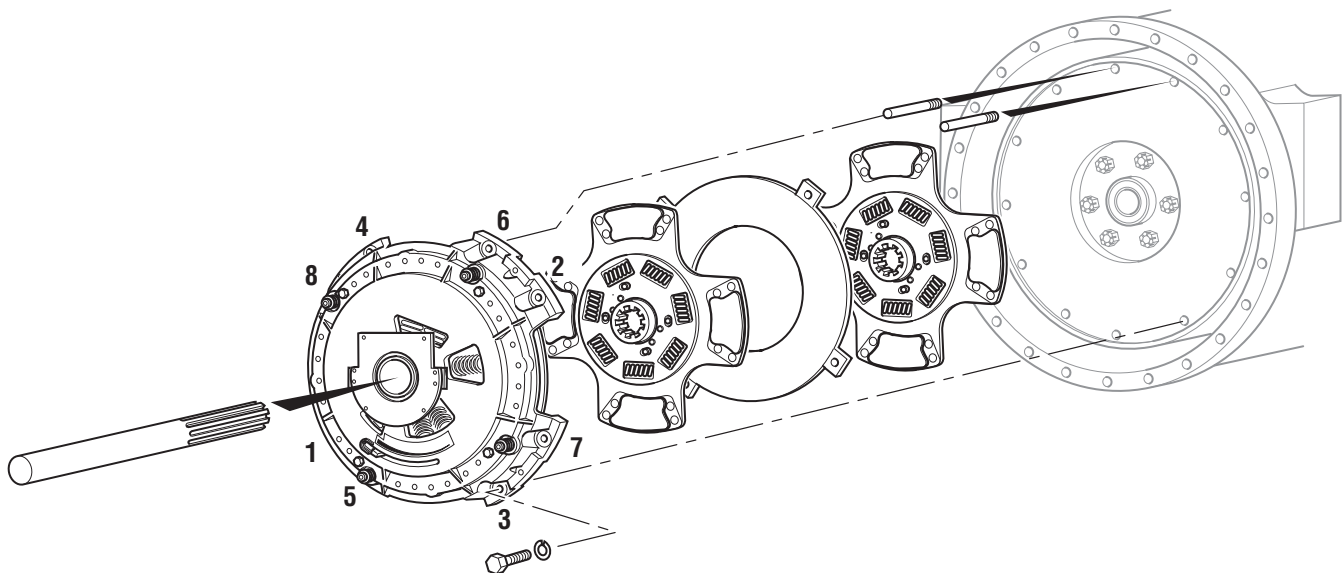

9. Progressively tighten mounting bolts in a crisscross pattern starting with the lower left bolt (1, 2, 3, 4, 5, 6, 7, 8). Torque to 40–50 lb-ft (54–68 N•m).

⚠ Caution: Failure to do this could result in improper piloting of the clutch to the flywheel and can result in a vibration, or worse, the clutch coming loose from the flywheel.

10. Remove four yellow shipping bolts in a crisscross pattern.

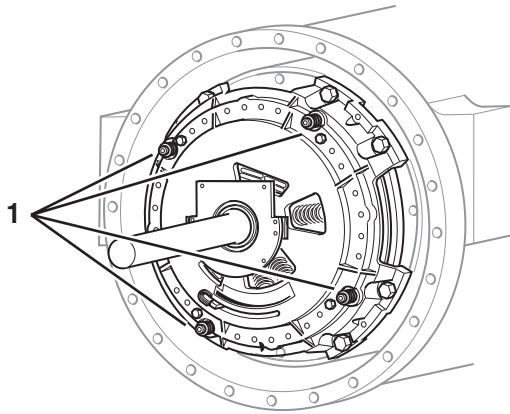

1. Yellow Shipping Bolts

11. Remove the aligning tool.

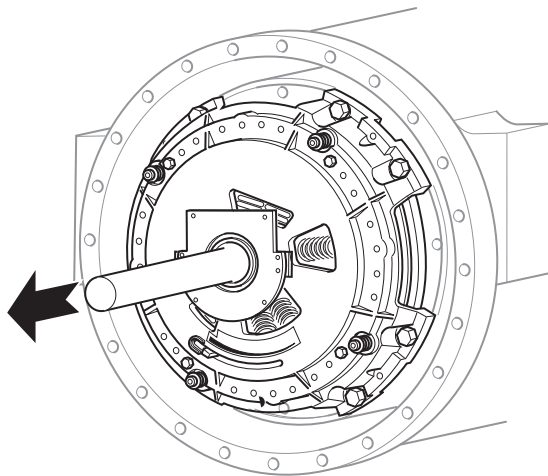

12. Use a 6 oz hammer and a 1/4" flat nose punch to lightly tap the four separator plate pins toward the flywheel. Only part of the pin should be visible. If installing an Advantage Self-Adjust Clutch, proceed to Step 1 for the Installation of the HD Advantage Lube Hose Attachment.

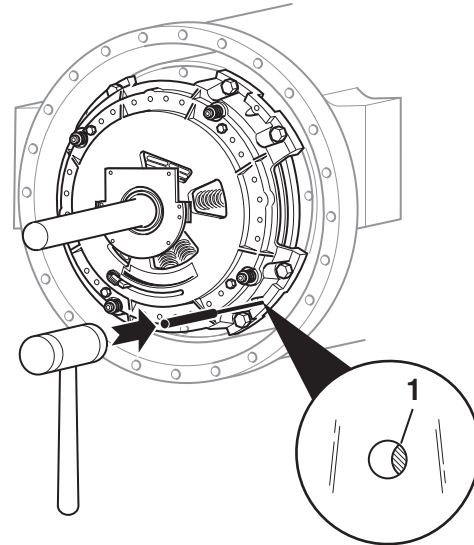

Heavy-Duty Self-Adjust Lube Hose Attachment

Note: The example shown is of a Lube Hose Attachment for a heavy-duty hydraulic release system.

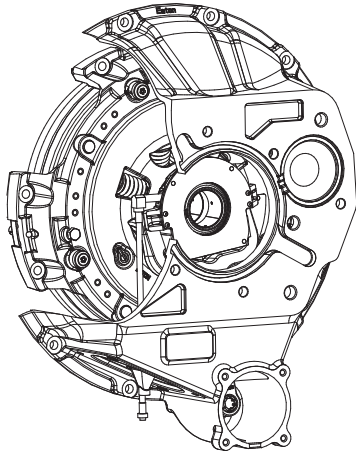

1. Install brass fitting into grease port on left side of release bearing housing using a Weatherhead socket. Hand tighten and continue to turn until the opening of the fitting is facing toward the 6 o'clock position.

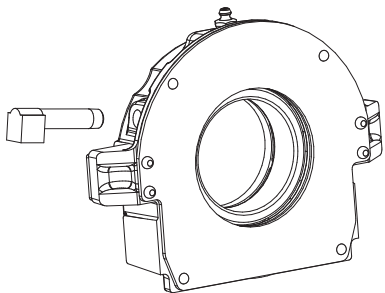

2. Install lube hose into brass fitting and tighten until hand tight, then turn an additional two turns while supporting the brass fitting.

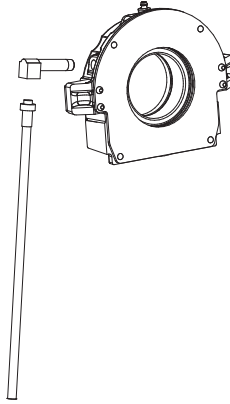

3. Lubricate release bearing until grease purges from release bearing housing. Use NLGI Grade 2 Lithium-complex grease With NLGI GC/LB certification.



Important: Eaton recommends the use of Roadranger EP2 for release bearing lubrication, or an equivalent Lithium Complex, NLGI #2 or #3 grease with a NLGI LB/GC performance rating and a dropping Point temperature of 220 C (428 F) or higher. Failure to use the proper grease may affect bearing life and void the warranty coverage on your Eaton product.



Important: If remote grease tube is utilized Eaton requires that the inspection cover be removed during greasing procedure to ensure that the release bearing is purging grease properly

Note: A hand hole cover with grommet or plug is required with HD Advantage.

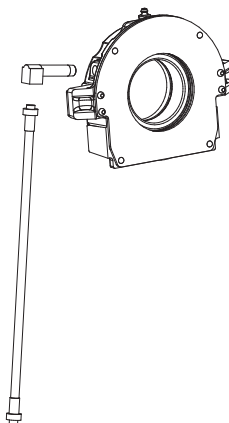

Transmission

Inspect Transmission for Wear

1. Replace any worn components.
2. Inspect the transmission bearing retainer cap. A worn/rough bearing retainer cap may cause the clutch brake to wear prematurely or affect proper clutch setup.
3. Inspect the cross shaft and bushings. Excessive wear at these points can cause side loading on the sleeve bushing, bushing failures and yoke bridge contact with the clutch when the pedal is down or affect proper clutch setup.
4. Inspect the shaft splines. Any wear on the splines will prevent the driven discs from sliding freely, causing poor clutch release (clutch drag). Slide discs full length of shaft to check for twisted shaft splines or affect proper clutch setup.

⚠ Important: Do not add lube (anti-seize or grease) to the input shaft splines. The discs must be free to move.

5. Inspect the input shaft spigot. Wear will not provide proper interface with the inner race of the pilot bearing. This can result in damage to the clutch or the pilot bearing.
6. Replace the clutch brake.

7. Measure the input shaft. Length should be 8.657" (219.89 mm) nominal, and not greater than 8.71" (221.23 mm). Ref. 1990 SAE handbook 4:36.106. Replace transmission bearing retainer cap if length is greater than 8.71" (219.89 mm).
8. Inspect the input shaft. Wear (roughness) can reduce sleeve bushing life and cause it to come out.
9. Inspect the release yoke. Worn fingers can cause bushing wear and yoke interference when the pedal is down or affect proper clutch setup.

⚠ Caution: Do not excessively force the transmission into the clutch assembly or engine housing. This will cause damage to the splines of the rear disc hub that is not warrantable. If the discs do not slide freely in the input shaft, investigate the cause of the problem and make any necessary changes. If the discs do not slide freely, the clutch will not release and the transmission will grind going into gear.

⚠ Caution: Do not let the transmission drop or hang unsupported in the driven discs. This can bend the discs, and the clutch will not release, causing damage that is not warrantable.

⚠ Caution: Do not use the cross shaft release lever (or a pipe over it) to pull the transmission into its final position. Pulling the bearing prior to the transmission being bolted to the engine flywheel housing will result in an over adjust of the Self-Adjust clutch assembly. The release bearing gap to the clutch brake will be (less than 0.490") with this condition. Follow the In-Vehicle Resetting procedure on page page 53.

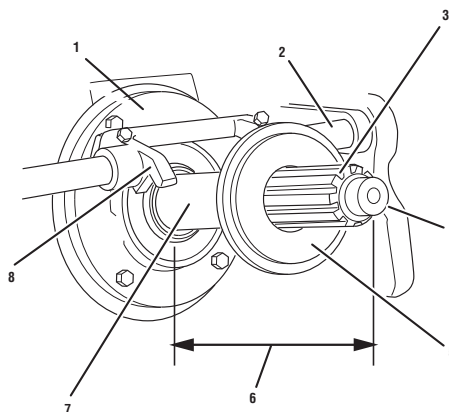

1. Transmission Bearing Cap
2. Cross Shaft and Bushings
3. Input Shaft Splines
4. Input Shaft Spigot

5. Clutch Brake
6. Measure Input Shaft
7. Input Shaft

Fasten Transmission to Flywheel Housing

⚠ Important: Before installing the transmission, be sure to plug or close all unused openings in the clutch housings.

1. Put transmission in gear. Make sure new clutch brake has been installed.

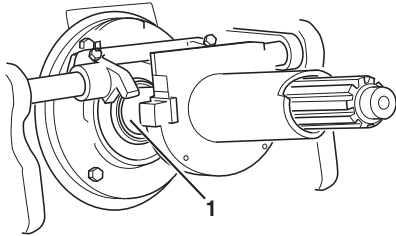

1. Clutch Brake

2. Make sure that the yoke fingers remain in the up position until they are over the release bearing housing.

⚠ Caution: Do not force transmission against clutch with yoke fingers in the up position. This will break the cast webbing of the clutch causing damage that is not warrantable.

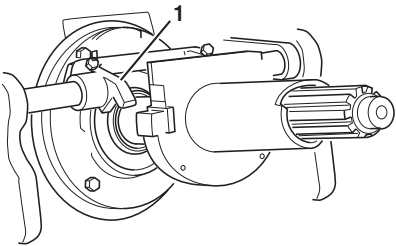

1. Yoke Fingers

3. Insert plug into hole in the upper left side of the clutch housing where the horizontal lube hose is utilized. (Image not shown.)

Note: If the lube hose assembly should need servicing, it can be replaced without removal of the transmission.

4. Position transmission so it is square to and aligned with engine.

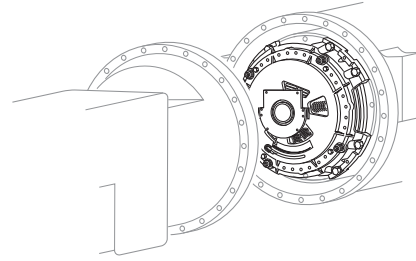

5. Mesh splines by moving transmission forward and rotating the output shaft.

⚠ Important: Do not add lube (anti-seize or grease) to the input shaft splines. The discs must be free to move.

⚠ Caution: Do not pull on release arm to install transmission. This will cause the clutch to overadjust.

⚠ Caution: Do not use excessive force. If it does not enter freely, investigate the cause of problem and make any necessary changes.

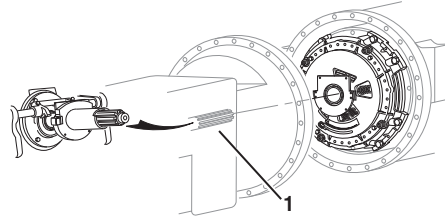

1. Output Shaft

6. Install mounting bolts and torque to OEM specs.

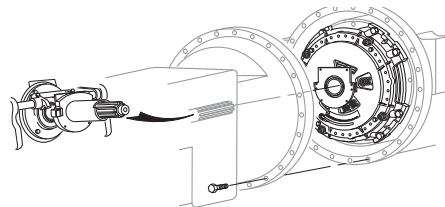

7. Install hand hold cover A-8173 with grommet positioned toward rear of hand hold opening in the clutch housing. Secure the hand hole cover with two 5/16" x 18 x 1/2" long bolts.

Evertough®, Value Clutch, Reman Self-Adjust Clutches

Special Instructions

None

Special Tools

None

Clutch Set-up

Adjust Clutch Linkage

⚠ Important: Inspect mechanical linkage for worn, loose or binding components. Inspect hydraulic linkage for leaks, contamination of fluid, damaged components and air in the system. Reference OEM service manuals for servicing of these components.

1. For mechanical linkages only, adjust the clutch linkage until the yoke fingers contact the release bearing (zero free-play in cab). For hydraulic linkages, go to Step 2.

2. Press the pedal to the floor up to five times. For mechanical linkages only, doing this gains free-play in the cab.

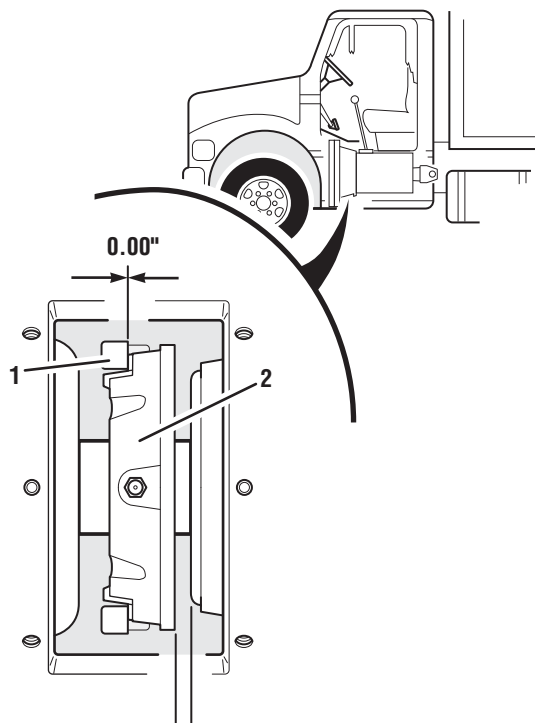

1. Yoke Finger
2. Release Bearing

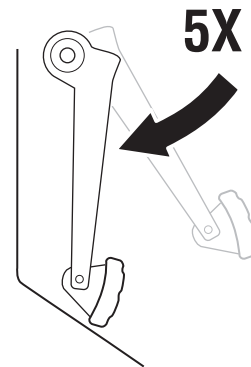



3. With the pedal up, measure the distance between the release bearing and the clutch brake. The correct distance should be 0.490"–0.560" (12.70–14.22 mm):

- If the distance is more than 0.560" (14.22 mm), return to Step 1 and readjust the clutch linkage. (For hydraulic linkages, verify that the linkage will stroke the bearing far enough for the initial adjustment to occur.)
- If the distance is less than 0.490" (12.70 mm), finish the install then see Advantage Self-Adjust Heavy-Duty 15.5" Clutch Troubleshooting.

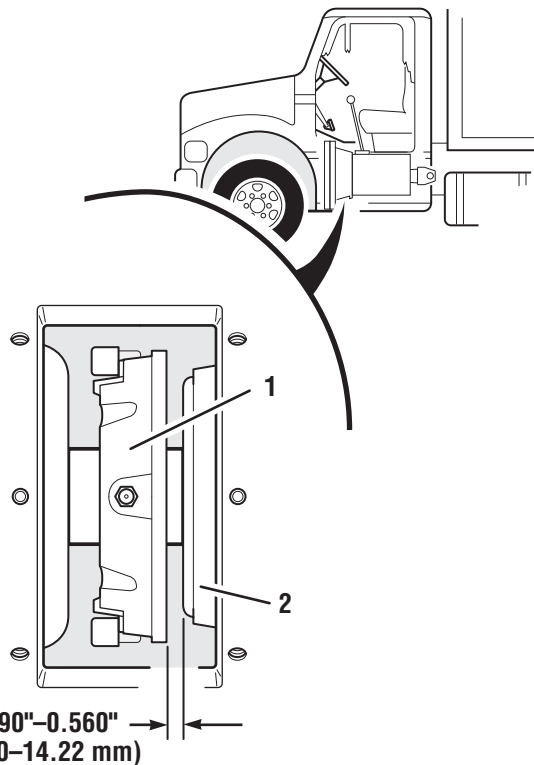

1. Release Bearing
2. Clutch Brake

4. Verify that the wear indicator has moved out of the new position.

Verify Clutch Brake Squeeze

Warning: Use a gauge long enough to keep hands away from moving parts.

1. Have an assistant insert 0.010" (0.25 mm) feeler gauge between the release bearing and the clutch brake. Press the pedal down to the floor:
 - For mechanical linkage, if the gauge does not clamp, readjust the truck linkage and move yoke fingers closer to the bearing.
 - For hydraulic linkage, skip this procedure and go to the "Lubricate" section on the next page.

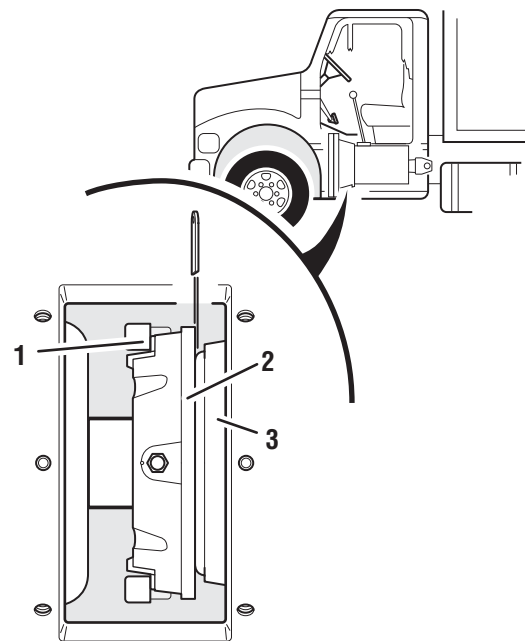

1. Yoke Finger
2. Release Bearing
3. Clutch Brake

2. For mechanical linkage only, slowly let up on the pedal and measure the pedal position at the moment the gauge can be removed:

- If pedal is more than 1" (25.4 mm) from the floor, readjust the truck linkage to move the yoke fingers further from the release bearing. Return to Step 1.

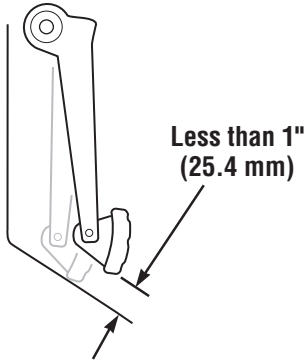

3. Verify for finger travel. For mechanical linkage only, measure gap at both sides of the release fork fingers. Gap should be 0.065" to 0.125". If not able to achieve this final adjustment, evaluate vehicle linkage system for worn, loose or improperly adjusted pedal stops.

⚠ Important: If release bearing travel is within specification of 0.490" to 0.560", do not reset the clutch.

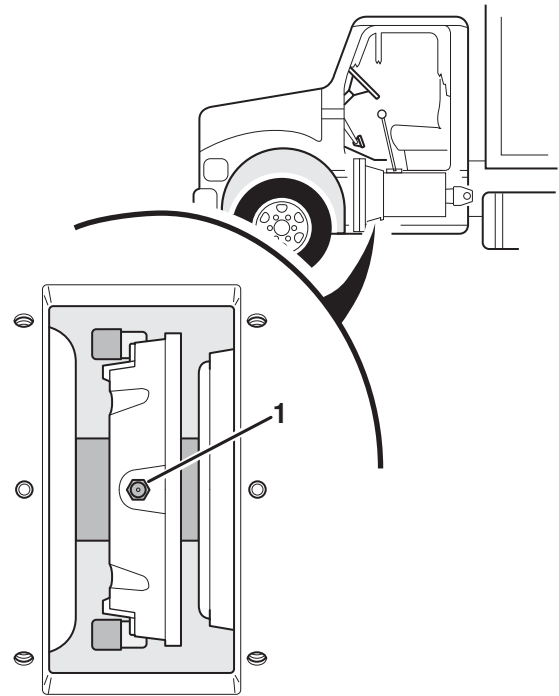

1. Release Bearing

Lubricate

Note: All clutches use a Lithium complex grease with a minimum of 325° F (163° C) operating range meeting NLGI Grade 2 or 3 specs. For additional lubrication information, see TCMT0021.

⚠ Caution: Failure to properly lubricate the bearing/bushing will result in bearing and sleeve failures. Using greases that are not compatible with the Eaton recommended grease can result in release bearing and bushing failures.

1. Release bearing lubrication: Apply grease through either the lube tube or a grease fitting, and continue to apply lube to cause enough grease to purge out of the release bearing housing onto the transmission input shaft. This will lube the clutch brake and bushing when the pedal is pressed.

2. Apply grease to yoke fingers.

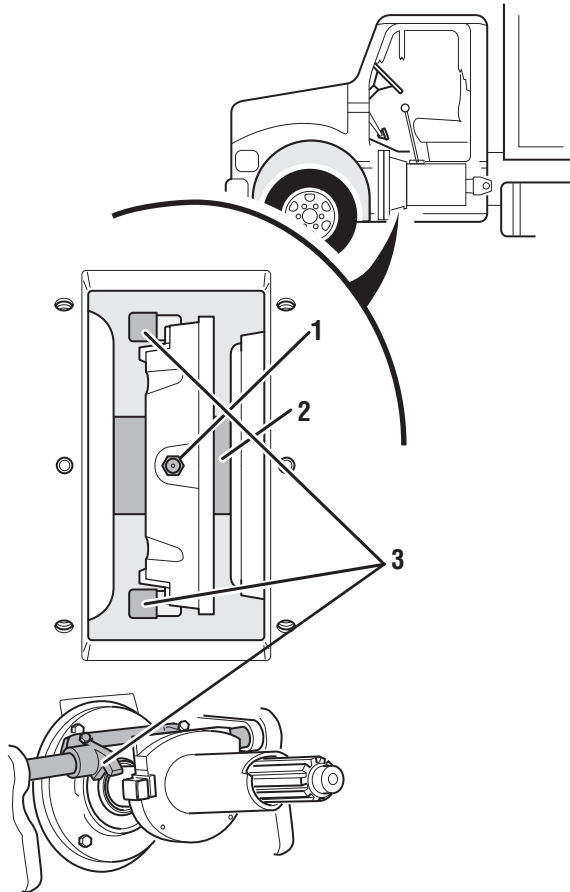

1. Zerk
2. Input Shaft
3. Yoke Fingers

3. Apply grease to the cross shaft bushings and linkage pivot points.

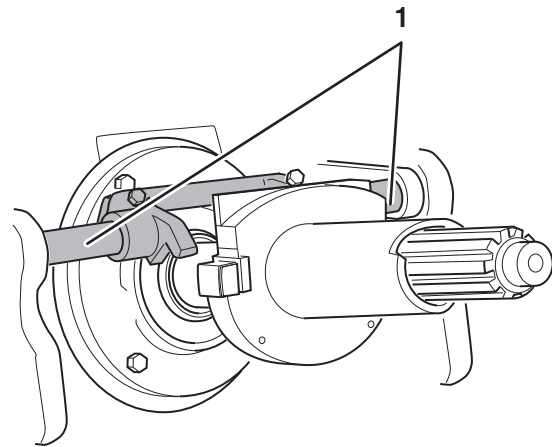

1. Cross Shaft Bushings and Linkage Pivot Points

Evertough®, Value Clutch, Reman Self-Adjust Clutches

Special Instructions

None

Special Tools

None

Clutch Troubleshooting Procedures

Symptom-Driven Diagnostics

1. If the clutch is out of the vehicle, go to Out-of-Vehicle Resetting procedure. Based on your symptom, the following steps will direct you to the correct solution.
2. If the pedal travels too far before engaging the clutch or the clutch does not disengage, then there is too much free pedal.

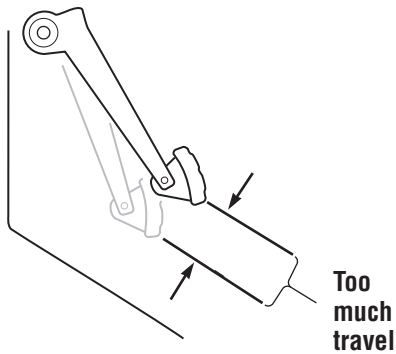

3. If the pedal travels too little before engaging the clutch, then there is too much free pedal.

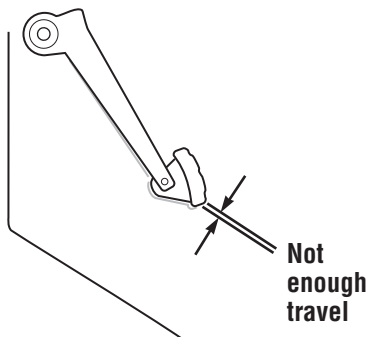

4. Not enough brake squeeze.

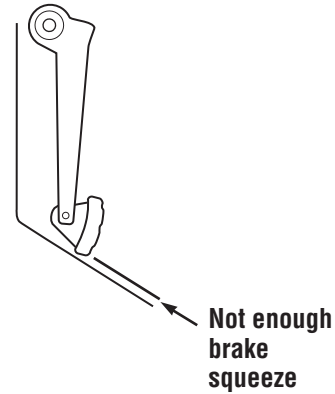

5. Not enough brake squeeze.

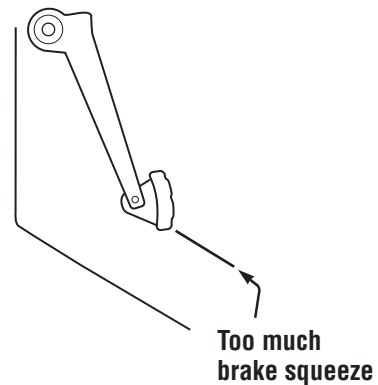

6. Measure distance between release bearing and clutch brake, then use the table on the next page to find the solution to the problem.

Note: Before measuring the distance between the release bearing and clutch brake, depress clutch pedal to remove free pedal in the cab. This will provide an accurate measurement for the gap between the release bearing and the clutch brake.

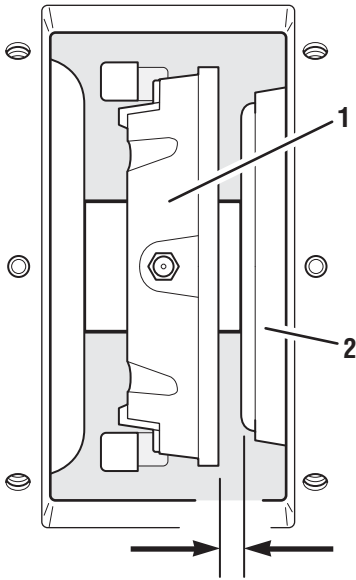

1. Release Bearing
2. Clutch Brake

Evertough®, Value Clutch, Reman Self-Adjust Clutches

Special Instructions

None

Special Tools

None

Clutch Resetting Procedures

In-Vehicle Resetting

1. Determine if the release bearing travel is correct. Measure the distance between the clutch brake and the release bearing with the clutch pedal up. If the measurement is between 0.490" and 0.590", the Self-Adjust clutch has set itself correctly.
2. If the release bearing travel is less than 0.490", the Self-Adjust Clutch must be reset. A common cause of this is the transmission was pulled in with the release arm during clutch installation.

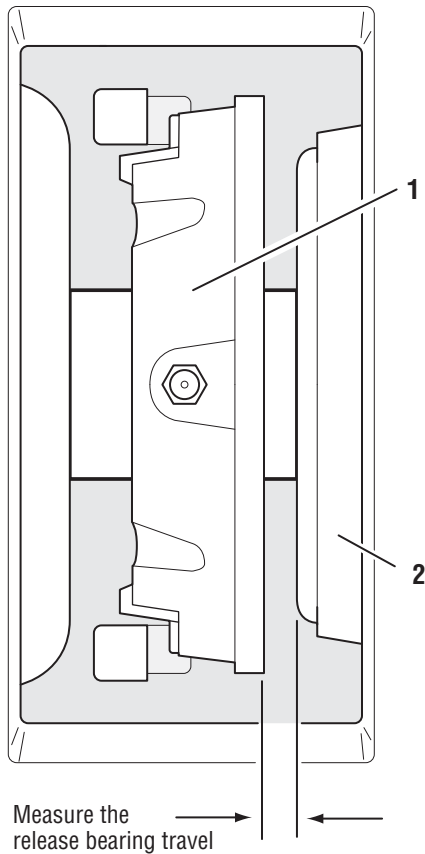

1. Release Bearing
2. Clutch Brake

3. Rotate the engine so that the cam tab can be reached through the transmission inspection opening.
4. Push the clutch pedal to the floor. While the clutch pedal is pushed to the floor, have someone push the cam tab to the new position using finger pressure. Once the cam tab is pushed to the new position, you can release the clutch pedal.

Note: If using a tool to assist with movement of the cam to the new position, use a blunt tool that will not damage the cam.

Note: If the cam tab does not move, there is not enough release bearing travel to allow the cams to separate. In this case, loosen the transmission and install 1/2" spacers between the flywheel housing and bell housing.

With the spacers in place, push the clutch pedal to the floor while someone pushes the cam tab to the new position. Once the tab is in the raised area at the new position, release the clutch pedal and remove the spacers. Torque the transmission mounting bolts.

Caution: Support the transmission with an appropriate jack or lifting device to prevent damage to the clutch cover and driven disc.

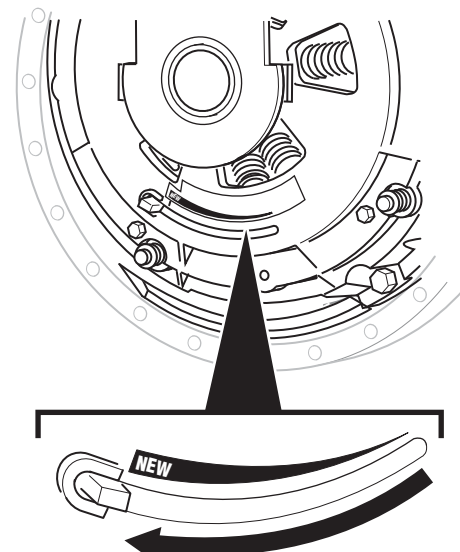

5. Install four shipping bolts and progressively tighten until they bottom out.

Caution: Only use hand tools to tighten shipping bolts. Do not use air tools.

Rotate the engine to access all four bolts:

- 15 1/2" Self-Adjust Clutch uses 7/16 x 14 UNC x 1 3/4"
- Stamped 14" Self-Adjust Clutch uses 3/8 x 16 UNC x 1 1/4"

Note: This will reset the pressure plate separator pins and allow the clutch to release after installation.

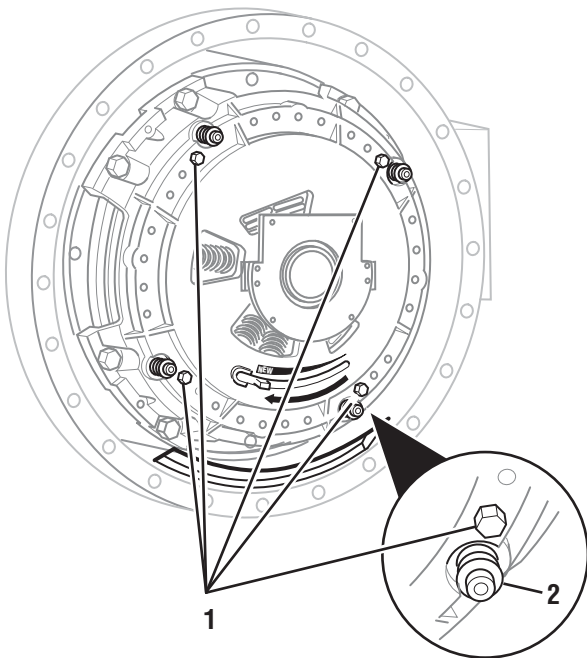

1. Shipping Bolts
2. Tamper-Proof Bolts

6. Remove the four shipping bolts. The release bearing and sleeve will move forward toward the engine when the bolts are removed. The clutch is now in the new position.

Note: If the procedure was performed correctly, the gap between the release bearing and the clutch brake should be about 0.750".

7. With the free pedal removed, push the clutch pedal down at least five times. Make sure the clutch release bearing contacts the clutch brake.

Note: For mechanical linkage, while engaging and releasing the clutch, the cab free pedal will increase. This indicates the clutch is adjusting to the environment.

Note: For hydraulic linkage, be sure to stroke the clutch pedal all the way to the floor, ensuring that the release bearing is being stroked far enough for the clutch to make an adjustment. With a hydraulic release system there will be no change in free pedal when the self-adjust clutch makes an adjustment.

8. Measure the distance between the clutch brake and the release bearing. It should be between 0.490" and 0.590".
9. If the release bearing travel is still greater than 0.590" between the clutch brake and the release bearing, repeat Steps 7 and 8.
10. For mechanical linkages, adjust the clutch linkage to achieve 1/8" clearance between the release yoke and the release bearing. Verify proper clutch brake squeeze.

Verify Clutch Brake Squeeze

Warning: Use a gauge long enough to keep hands away from moving parts.

1. Have an assistant insert 0.010" (0.25 mm) feeler gauge between the release bearing and the clutch brake. Press the pedal down to the floor to clamp the gauge:
 - If the gauge does not clamp, readjust the truck linkage and move the yoke finger closer to the bearing.

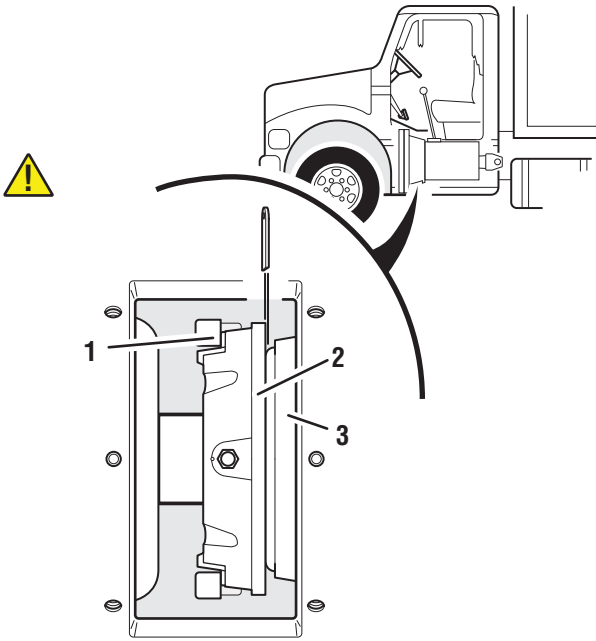

1. Yoke Finger
2. Release Bearing
3. Clutch Brake

2. Slowly let up on the pedal and measure the pedal position at the moment the gauge can be removed:
 - If pedal is more than 1" (25.4 mm) from the floor, readjust the truck linkage to move the yoke fingers further from the release bearing. Return to Step 1.

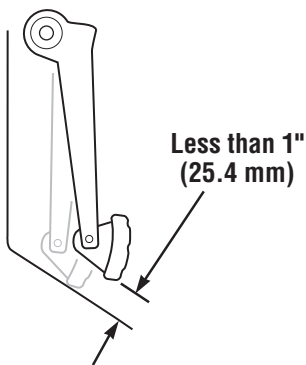

Out-of-Vehicle Reset Procedure for Heavy-Duty ECA or Advantage Self-Adjust Clutches (Using an Arbor Press)

1. Support the clutch in an arbor press with the bearing facing down.

⚠ Important: Make sure there is at least 1" of space to allow the bearing to move down and to provide access to the shipping bolts.

2. Center the ram and press downward on the retainer until it comes to a stop. Lock the ram in position.

Caution: Depressing the retainer too far may damage the cover assembly.

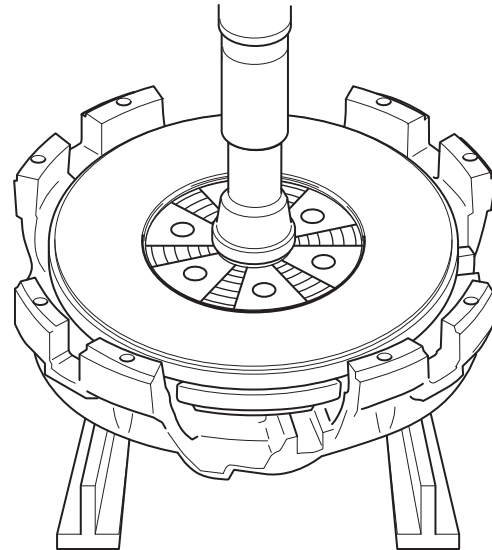

3. Remove the four shipping bolts if they have been installed.

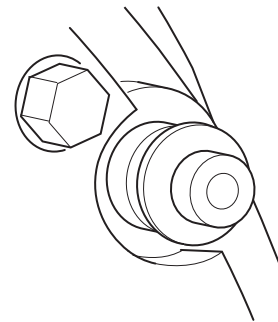

4. Slide the wear indicator tab to the "NEW" position and hold it in place with a magnet.

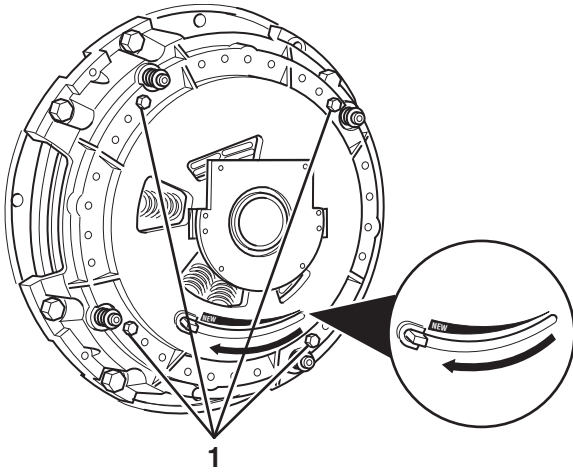

1. Shipping Bolts

5. Install the four shipping bolts (7/16" x 14 x 1-3/4" UNC, hex head). Progressively tighten (no air wrenches) the four shipping bolts (crisscross pattern) until the bolts are tight. Reference illustration for pressure plate position.

Note: This important step will reset the pressure plate separator pins and allow the clutch to release after re-installation.

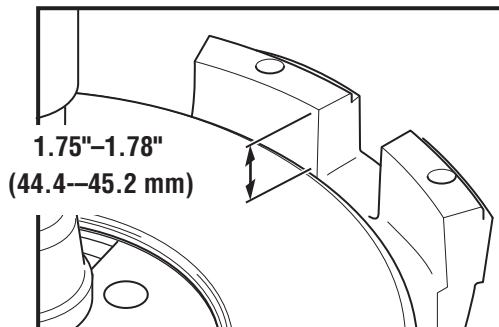

6. Reinstall the clutch using the original installation instructions.

Evertough®, Value Clutch, Reman Manual Adjust Clutches

Special Instructions

None

Special Tools

None

Clutch Removal

Note: If clutch is to be reinstalled and transmission is still in vehicle, follow this procedure.

Warning: An assembled clutch weighs approximately 150 lb (68 kg). Avoid the risk of injury. Use proper equipment when lifting a clutch.

Caution: Note the position of the wear indicating tab on the clutch. If the tab is near the “REPLACE” position, the clutch should be replaced.

1. Insert appropriate clutch alignment tool.
2. Locate the four shipping bolts (7/16" x 14 x 1 3/4" UNC, hex head). Hand tighten them into the four cover holes, then turn one full turn.

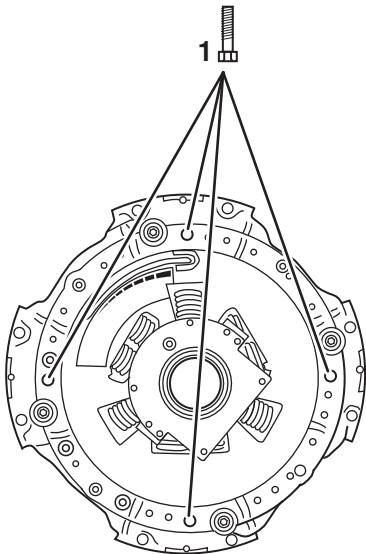

1. Shipping Bolts

3. Remove two of the top mounting bolts and install two 7/16" x 14 x 5" studs. Then remove the remaining six mounting bolts.
4. Remove the clutch from the flywheel.

Note: Mark the proper position of the discs and intermediate plate (for re-installation).

Evertough®, Value Clutch, Reman Manual Adjust Clutches

Special Instructions

None

Special Tools

None

Clutch Installation

! **Important:** For machining of the flywheel friction surface contact the OEM engine manufacture for specifications.

Measure Engine Flywheel Housing and Flywheel

! **Important:** Engine flywheel housing and flywheel must meet these specifications or it may result in premature clutch failure.

1. Remove and replace old pilot bearing per engine manufacturer instructions.
2. All gauge contact surfaces must be clean and dry. Clean flywheel surfaces of all grease, oil and rust preventatives. Failure to perform this function can affect the performance of the clutch.
3. Contact OEM engine manufacture for specific instructions for dial indication of the flywheel and flywheel housing.
4. Use a dial indicator to check the flywheel face runout.
 - a. Secure dial indicator base to flywheel housing face.
 - b. Put gauge finger in contact with flywheel face near the outer edge.
 - c. Rotate flywheel one revolution. Maximum runout is 0.008" (0.20 mm).

5. Use a dial indicator to check the pilot bearing bore runout.
 - a. Secure dial indicator base to flywheel housing face.
 - b. Position gauge finger so that it contacts pilot bearing bore.
 - c. Rotate flywheel one revolution. Maximum runout is 0.005" (0.13 mm).

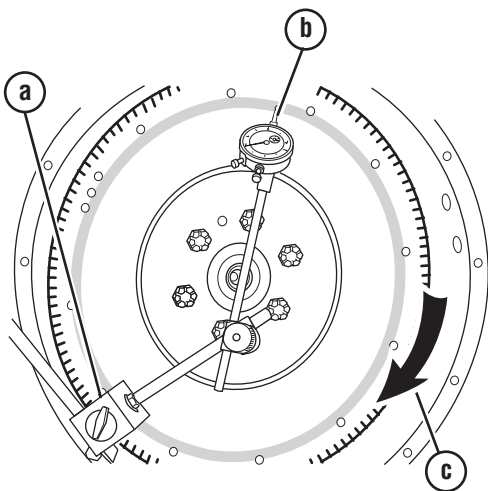
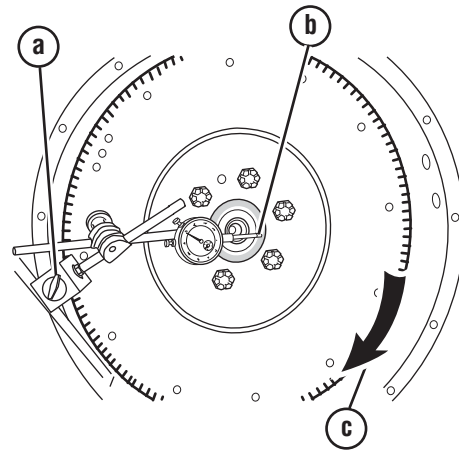

6. Use a dial indicator to check the flywheel housing I.D. runout.
 - a. Secure dial indicator base to crankshaft.
 - b. Put gauge finger against flywheel housing pilot I.D.
 - c. Rotate flywheel one revolution. Maximum runout is 0.012" (0.30 mm).

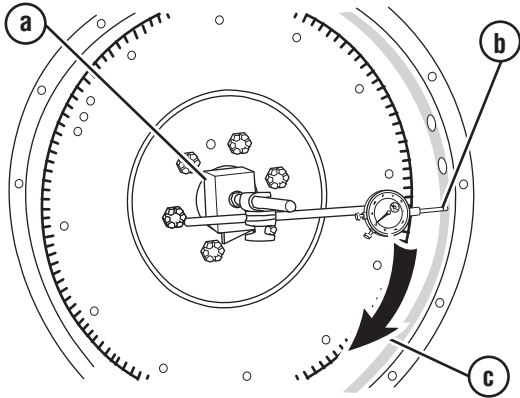

7. Use a dial indicator to check the flywheel housing face runout.
 - a. Secure dial indicator base to flywheel near the outer edge.
 - b. Put gauge finger against flywheel housing pilot.
 - c. Rotate flywheel one revolution. Maximum runout is 0.008" (0.20 mm).

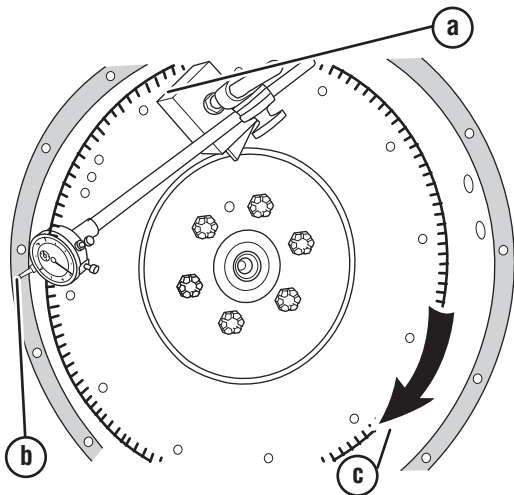

Evertough®, Value Clutch, Reman Manual Adjust Clutches

Special Instructions

None

Special Tools

None

Install Clutch to Flywheel



Important: Use the Eaton Clutch Selector Guide (CLSL1511) to make sure you have the right clutch. Reference “Clutch Guide for Installation of Eaton Clutch Products” in the Appendix.

Note: When installing clutch to flywheel, position the adjuster at the bottom of flywheel to ease future clutch servicing.

1. Install pilot bearing. Measure the flywheel bore. Use the Eaton Clutch Selector Guide (CLSL1511) to verify that the damper will fit into the flywheel bore.

Note: See the Appendix for a list of recommended pilot bearings.

Note: Mack 9-spring for Mack and Volvo engines 2007 and newer only.

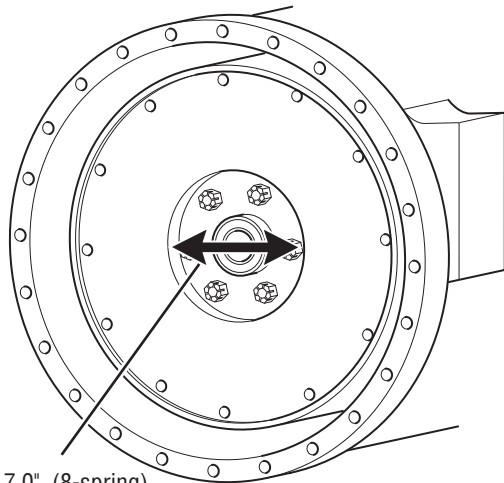

7.0" (8-spring)
8.5" (10-spring)
10.0" (7-spring and Mack 9-spring)

2. Insert aligning tool through bearing.

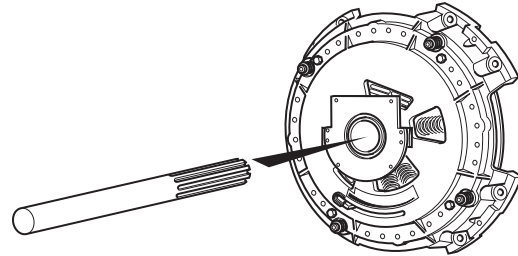

3. Install second disc onto aligning tool. Follow the orientation instructions on the disc.

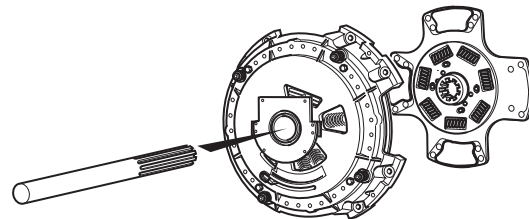

4. Install intermediate plate into slots on the clutch cover. Flywheel side must face the flywheel.

Note: Separator pins need to be positioned flush on side of intermediate plate facing the cover assembly.

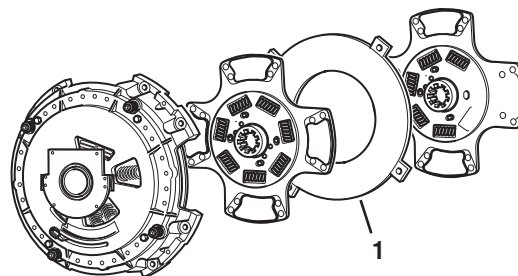

1. Intermediate Plate

5. Install second disc onto aligning tool. Follow the orientation instructions on the disc.

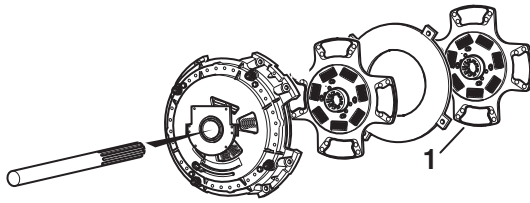

1. Second Disc

6. Install two 7/16" x 14 UNC x 5" studs into upper mounting holes. Install assembled clutch.

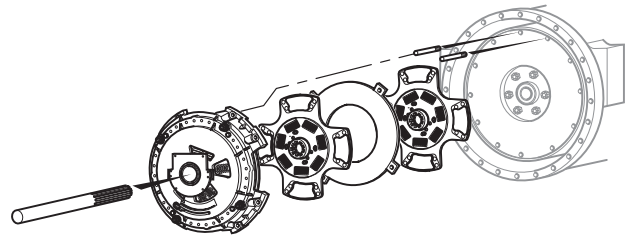

7. Install required lock washers and mounting bolts (7/16" x 14 UNC x 2-1/4" grade 5) finger tight. Replace studs with lock washers and bolts.

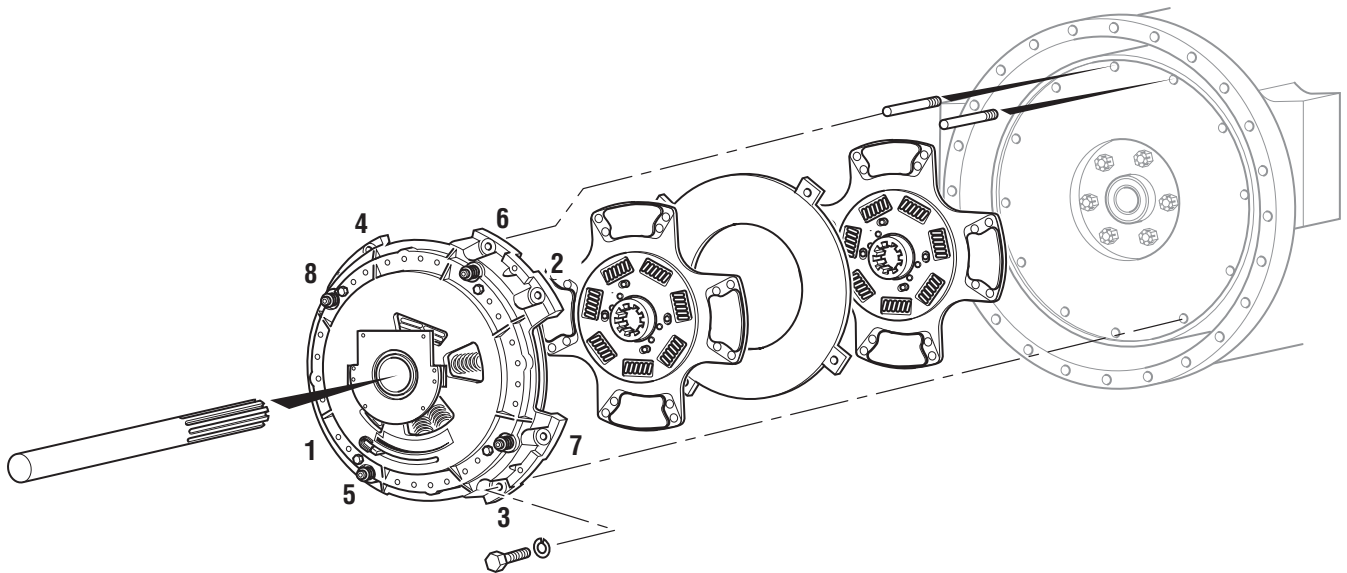

8. Progressively tighten mounting bolts in a crisscross pattern starting with the lower left bolt (1, 2, 3, 4, 5, 6, 7, 8). Torque to 40–50 lb-ft (54–68 N•m).

⚠ Caution: Failure to do this could result in improper piloting of the clutch to the flywheel and can result in a vibration, or worse, the clutch coming loose from the flywheel.

9. Verify bearing position is $3/8"$ – $5/8"$ (9.5–15.9 mm) from cover.

Note: If this dimension is out of specification, contact the Roadranger Call Center.

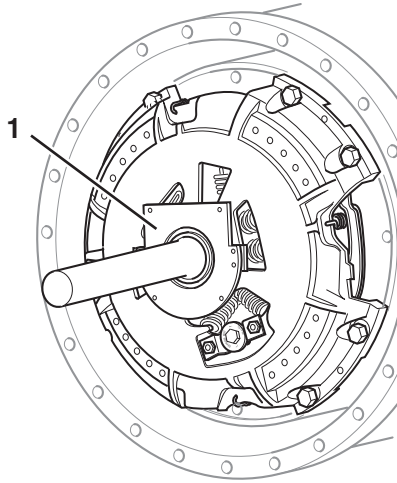

1. Bearing Position

10. Remove the aligning tool. Be sure shipping blocks are removed.

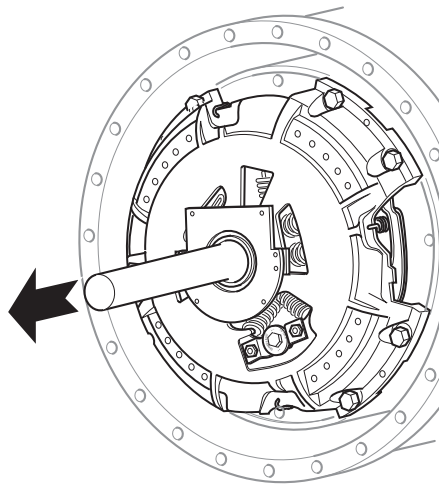

11. Use a 6 oz hammer and a $1/4"$ flat nose punch to lightly tap the four separator plate pins toward the flywheel. Only part of the pin should be visible. Install Lube hose attachments.

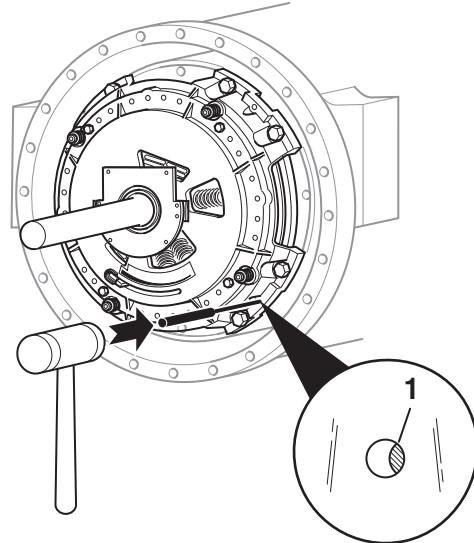

14" Clutch to Flywheel

Note: For the intermediate plate drive pin removal, refer to OEM for style of drive pins and locking mechanisms.

1. Ensure the correct flywheel depth is 2-15/16".
2. Put front disc into flywheel. Flywheel side must be toward engine. Use new slots to put intermediate plate on pins.

3. Turn intermediate plate left. Use 0.006" feeler gauge to check left pin clearance on all six drive pins.

Note: Remove two set screws. Straighten pins to increase clearance and reinstall set screws. Do not file slots.

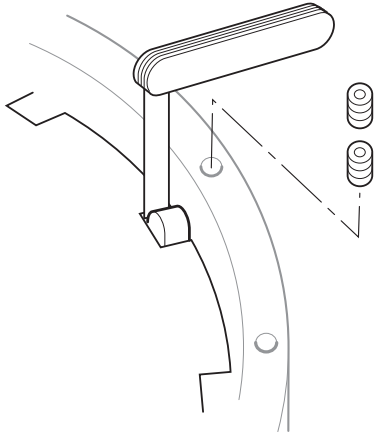

4. Install six 3/8" x 16 x 1/4" set screws. Then install second group of set screws to lock the lower set screw (typical set up). Verify with OEM if drive pin set up is different.
5. Install new pilot bearing. Reference the Appendix for list of recommended pilot bearings.
6. Install two 3/8" x 2-1/2" studs into upper mounting holes.

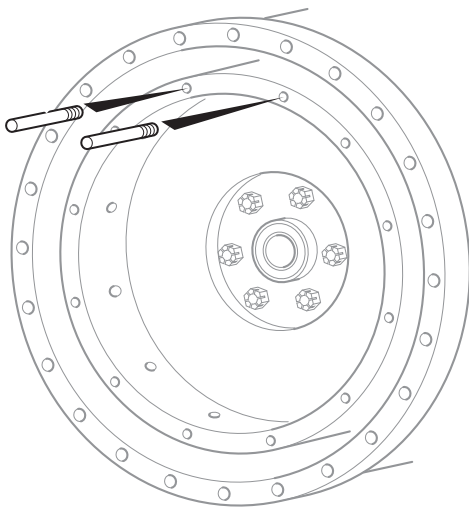

7. Install disc into flywheel. Follow the orientation instructions on the disc.

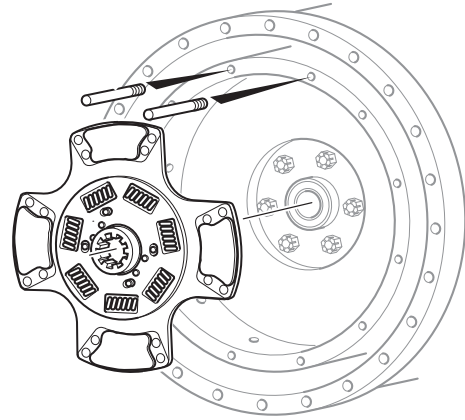

8. Install intermediate plate onto drive pins.

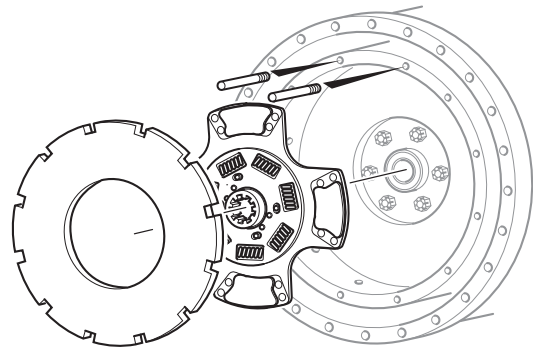

9. For the Super-Duty Clutch only, install three equally spaced anti-rattle springs.

Note: Check orientation on anti-rattle springs before installing.

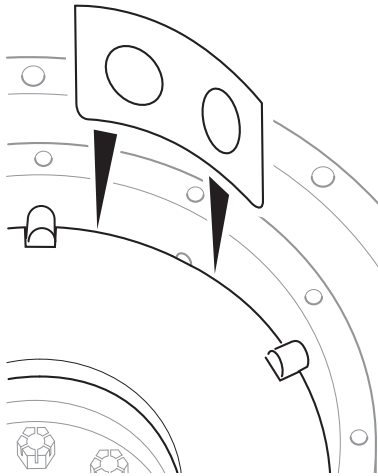

10. For the Super-Duty Clutch only, reinstall flywheel to engine referencing engine manufactures torque and run out specifications.
11. Install second disc onto flywheel. Follow the orientation instructions on the disc.

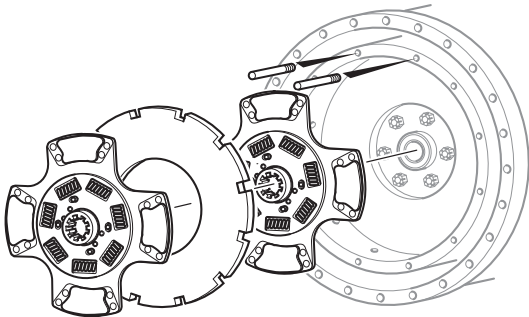

12. Insert aligning tool through discs. Be sure that the stub end of the alignment tool is inserted into the pilot bearing.

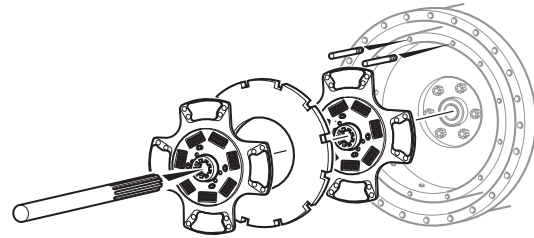

13. Slide cover over aligning tool.

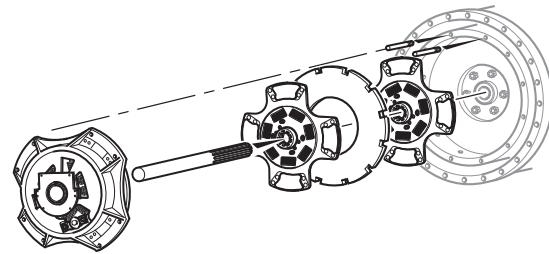

14. Install lock washers and mounting bolts (3/8" x 16 x 1-1/4" grade 5) finger tight. Replace studs with lock washers and bolts.

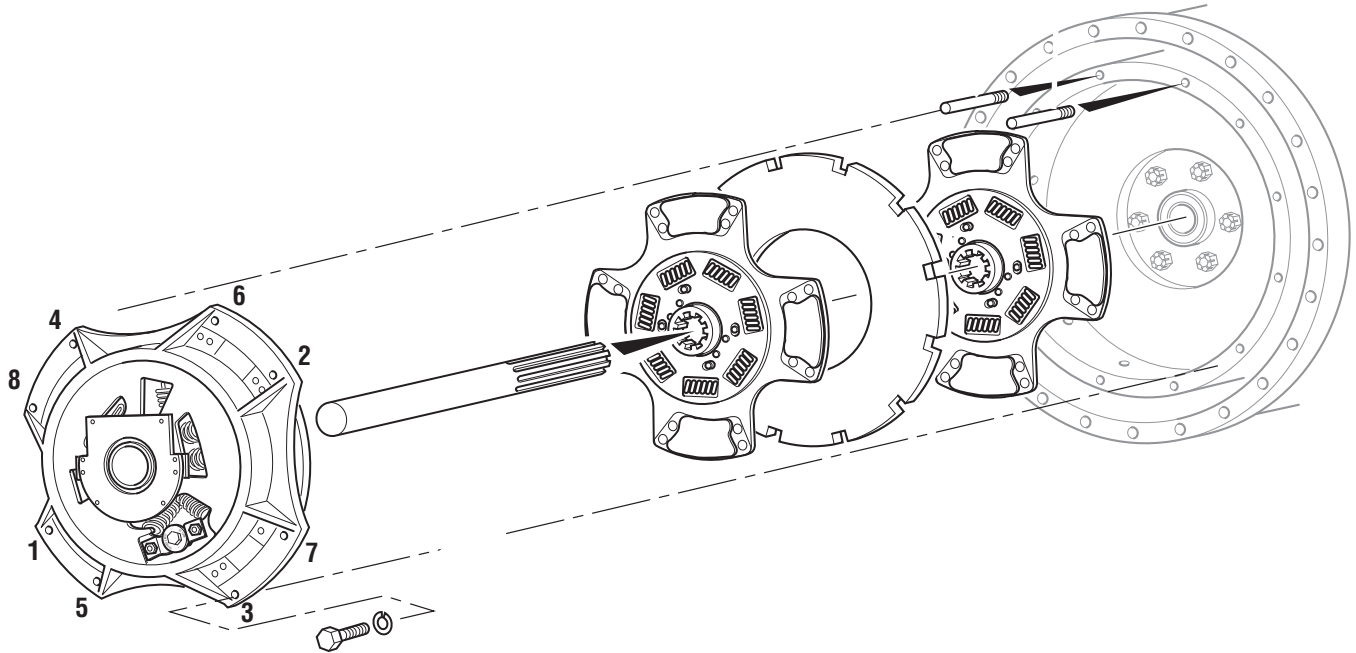

15. Progressively tighten mounting bolts in a crisscross pattern starting with the lower left bolt (1, 2, 3, 4, 5, 6, 7, 8). Torque to 25–35 lb-ft (34–47 N•m).



Caution: Failure to do this could result in improper piloting of the clutch to the flywheel and can result in a vibration or worse the clutch coming loose from the flywheel.

16. Remove the aligning tool. Be sure shipping blocks are removed.

Transmission

Inspect Transmission for Wear

1. Replace any worn components.
2. Inspect the transmission bearing retainer cap. A worn/rough bearing retainer cap may cause the clutch brake to wear prematurely or affect proper clutch setup.
3. Inspect the cross shaft and bushings. Excessive wear at these points can cause side loading on the sleeve bushing, bushing failures and yoke bridge contact with the clutch when the pedal is down or affect proper clutch setup.
4. Inspect the shaft splines. Any wear on the splines will prevent the driven discs from sliding freely, causing poor clutch release (clutch drag). Slide discs full length of shaft to check for twisted shaft splines or affect proper clutch setup.

⚠ Important: Do not add lube (anti-seize or grease) to the input shaft splines. The discs must be free to move.

5. Inspect the input shaft spigot. Wear will not provide proper interface with the inner race of the pilot bearing. This can result in damage to the clutch or the pilot bearing.
6. Replace the clutch brake.

7. Measure the input shaft. Length should be 8.657" (219.89 mm) nominal, and not greater than 8.71" (221.23 mm). Ref. 1990 SAE handbook 4:36.106. Replace transmission bearing retainer cap if length is greater than 8.71" (219.89 mm).
8. Inspect the input shaft. Wear (roughness) can reduce sleeve bushing life and cause it to come out.
9. Inspect the release yoke. Worn fingers can cause bushing wear and yoke interference when the pedal is down or affect proper clutch setup.

⚠ Caution: Do not let the transmission drop or hang unsupported in the driven discs. This can bend the discs, and the clutch will not release, causing damage that is not warrantable.

⚠ Caution: Do not excessively force the transmission into the clutch assembly or engine housing. This will cause damage to the splines of the rear disc hub that is not warrantable. If the discs do not slide freely in the input shaft, investigate the cause of the problem and make any necessary changes. If the discs do not slide freely, the clutch will not release and the transmission will grind going into gear.

Note: For most common vehicle linkages, the lube hose can be attached at the lower grease zerk location. For other linkage system, reference OEM instructions for lube hose attachment and routing.

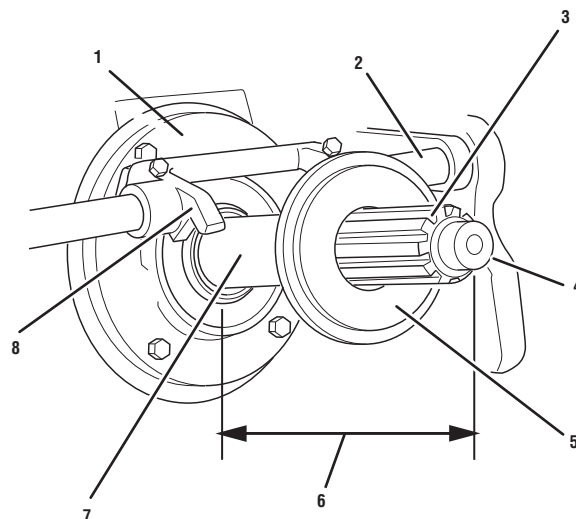

1. Transmission Bearing Cap
2. Cross Shaft and Bushings
3. Input Shaft Splines
4. Input Shaft Spigot

5. Clutch Brake
6. Measure Input Shaft
7. Input Shaft

Fasten Transmission to Flywheel Housing

Transmission installation and clutch set-up procedures are the same for the 14" and 15.5" clutch.

1. Put transmission in gear. Be sure new clutch brake has been installed.

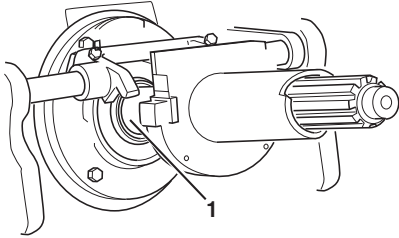

1. Clutch Brake

2. Make sure that the yoke fingers remain in the up position until they are over the release bearing housing.

Caution: Do not force transmission against clutch with yoke fingers in the up position. This will break the cast webbing of the clutch causing damage that is not war-rantable.

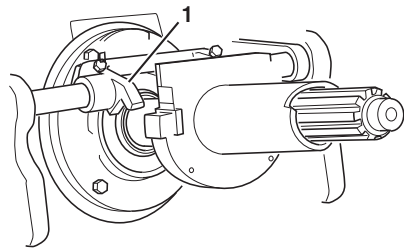

1. Yoke Fingers

3. Position transmission so it is square to and aligned with engine.

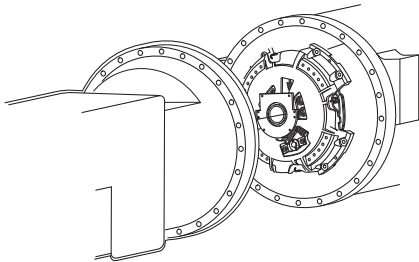

4. Mesh splines by moving transmission forward and rotating the output shaft. Do not use excessive force. Do not let the transmission hang unsupported in the discs.

Warning: Do not let the transmission drop or hang unsupported in the driven discs. This can cause the discs to become distorted and the clutch to not release.

Important: Do not add lube (ant-seize or grease) to the input shaft splines. The discs must be free to slide.

Caution: Do not use excessive force. If it does not enter freely, investigate the cause of problem and make any necessary changes.

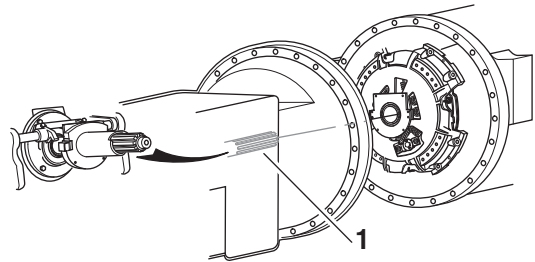

1. Output Shaft

5. Install mounting bolts and torque to OEM specs.

Note: Eaton does not recommend the use of manual adjusted clutches with hydraulic linkages. (Reference OEM information for hydraulic linkage.)

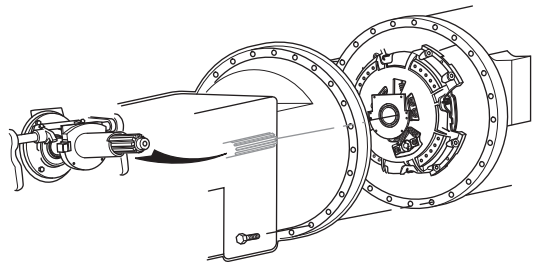

Evertough®, Value Clutch, Reman Manual Adjust Clutches

Special Instructions

None

Special Tools

None

Clutch Set-up

Adjust Bearing Position

Note: Before measuring the distance between the release bearing and clutch brake depress clutch pedal to remove free pedal in the cab.

1. Measure the distance between the release bearing and the clutch brake:
 - If the distance is correct, 0.500"–0.560" (12.70–14.22 mm), then Verify Clutch Brake Squeeze, go to Step 4.
 - If the distance is not between 0.500"–0.560" (12.70–14.22 mm), go to Step 2.

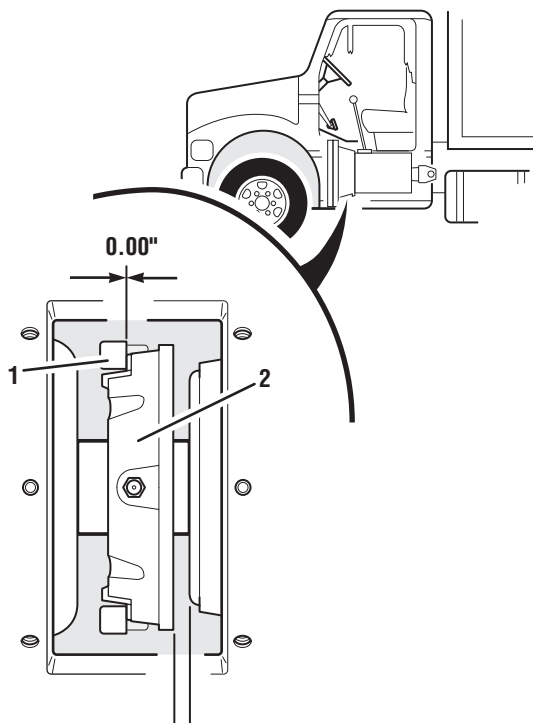

1. Yoke Finger
2. Release Bearing

2. Have an assistant hold down clutch pedal so internal adjustment can be made.

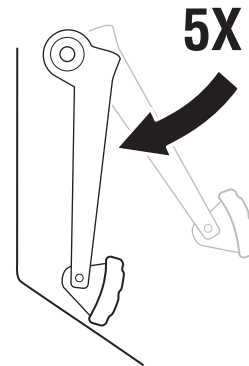

3. Adjust bearing position (clutch needs to be released so that the adjusting ring can be turned to change the gap between the release bearing and the clutch brake).
4. For the Easy-Pedal and Easy-Pedal Advantage only, while pedal is held down, push adjusting nut and turn (as viewed facing the engine):
 - If measurement was more than 0.560" (14.22 mm), turn adjusting nut clockwise.
 - If measurement was less than 0.500" (12.77 mm), turn adjusting nut counterclockwise.

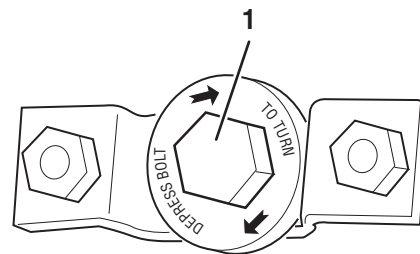

1. Adjusting Nut Part Number 125489

5. For the Value Clutch only, while pedal is held down, remove lockstrap and move adjusting lug:
 - If measurement was more than 0.560" (14.22 mm), move adjusting lug to the left (shown).
 - If measurement was less than 0.500" (12.77 mm), move adjusting lug to the right.

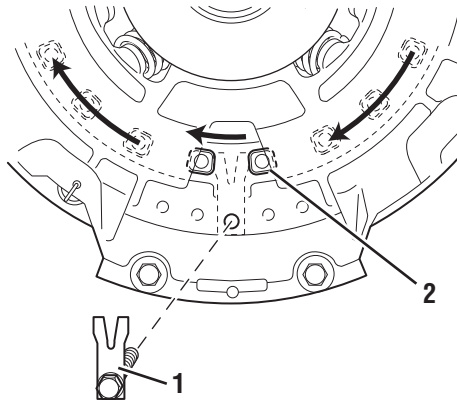

1. Lockstrap
2. Adjusting Lug

Verify Free-Play (Mechanical Linkage Only)

1. Measure the distance between yoke tips and bearing wear pads simultaneously. This distance should be 1/8" (3.2 mm). If distance is not 1/8" (3.2 mm), see Step 2.



Important: Do not change bearing position.

Note: 1/8" (3.2 mm) distance will create free-play in cab. Free-play in cab may be different on different truck makes, models and years.

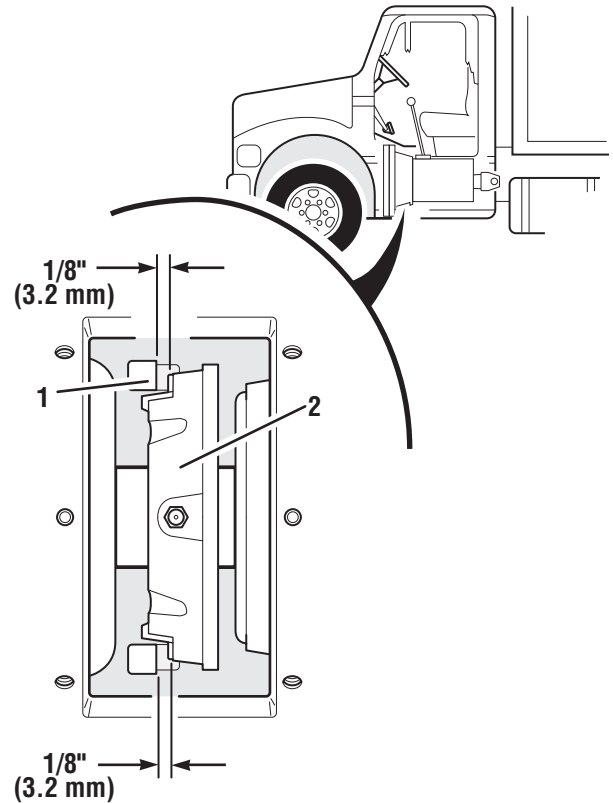

1. Yoke Finger
2. Release Bearing

2. The truck linkage should allow for a minimum of 0.685" of yoke finger movement; 0.125" for free-play, 0.500" for the bearing and 0.060" for clutch brake squeeze. If it is necessary to increase the free-play, adjust upper pedal stop to raise or lower the pedal in the cab. If this is not possible, check the OEM parts manual to verify the correct clutch arm was installed at the factory.

! **Important:** Do not change free-play by changing the bearing position. Correct bearing position is 0.500"–0.560" (12.70–14.22 mm).

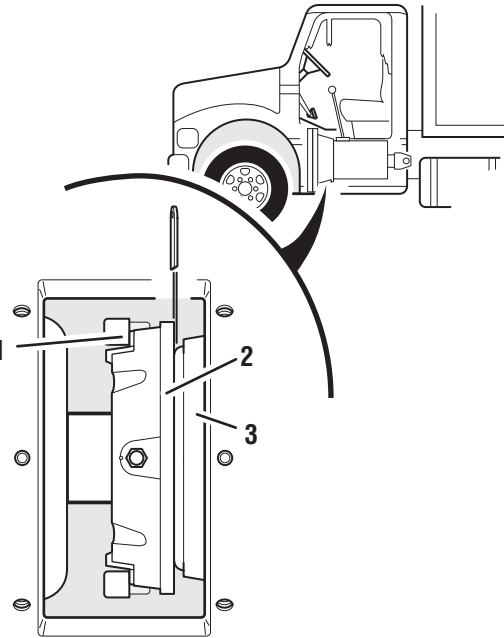
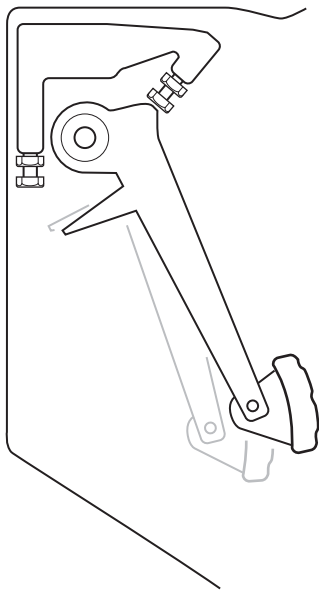

1. Yoke Finger
2. Release Bearing
3. Clutch Brake

Verify Clutch Brake Squeeze

! **Warning:** Use a gauge long enough to keep hands away from moving parts.

1. Have an assistant insert 0.010" (0.25 mm) feeler gauge between the release bearing and the clutch brake. Press the pedal down to the floor to clamp the gauge:
 - The truck linkage should allow for a minimum of 0.685" of yoke finger movement: 0.125" for free-play, 0.500" for the bearing and 0.060" for clutch brake squeeze. If it is necessary to increase the free-play, adjust the upper pedal stop to raise or

lower the pedal in the cab. If this is not possible, check the OEM parts manual to verify the correct clutch arm was installed at the factory. For hydraulic linkage, skip this procedure and go to the "Lubricate" section on the next page.

! **Important:** Do not change free-play by changing the bearing position. Correct bearing position is 0.500"–0.560" (12.70–14.22 mm).

2. Slowly let up on the pedal and measure the pedal position at the moment the feeler gauge can be removed:
 - Clutch brake engagement should be approximately 1" from end of pedal stroke.

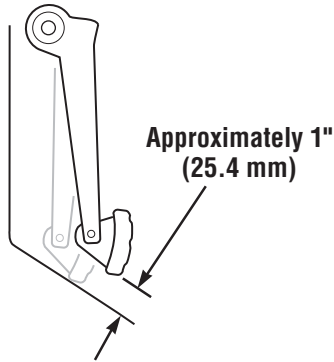

Lubricate

Note: All clutches use a Lithium complex grease with a minimum of 325° F (163° C) operating range meeting NLGI Grade 2 or 3 specs.

Note: Apply ample grease that is visibly exiting the opening and contacts the transmission shaft. This will lube the clutch brake and bushing when the pedal is pressed. For additional lubrication information, see TCMT0021

Caution: Failure to properly lubricate the bearing/bushing will result in bearing and sleeve failures.

3. Apply grease to yoke fingers.

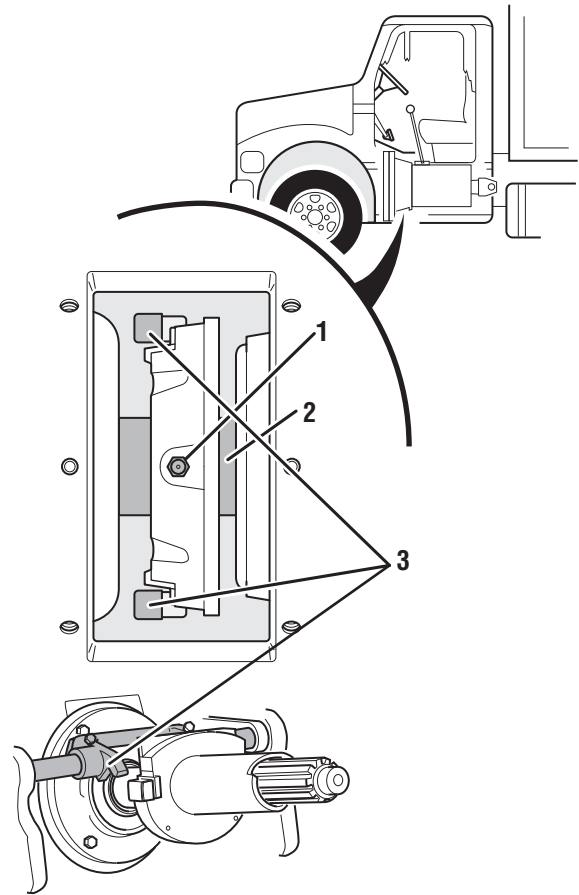

1. Zerk
2. Input Shaft
3. Yoke Fingers

4. Apply grease to the cross shaft bushings and linkage pivot points.



Important: Do not add lube (anti-seize or grease) to the input shaft splines. The disc must be free to move.

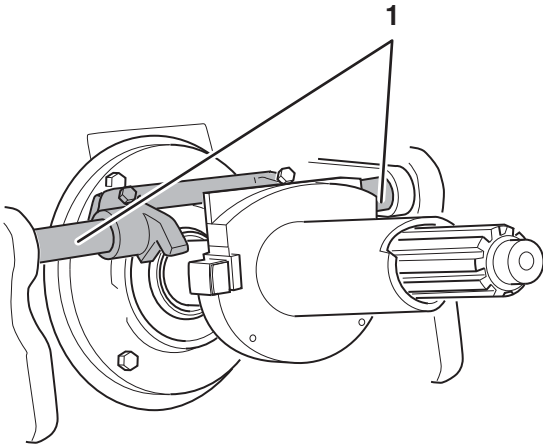

1. Cross Shaft Bushings and Linkage Pivot Points

UltraShift® DM Heavy-Duty Clutch

Special Instructions

None

Special Tools

None

Clutch Removal

Warning: An assembled clutch weighs approximately 182 lb (82 kg). Avoid the risk of injury. Use proper equipment when lifting a clutch.

Note: The following procedure should be followed if servicing the transmission and the clutch is not being removed from the flywheel. If the clutch is being replaced, go to Step 4, followed by Step 7.

1. Prior to removing the transmission, rotate the engine until one of the jack screw locations can be viewed through the clutch housing inspection opening.

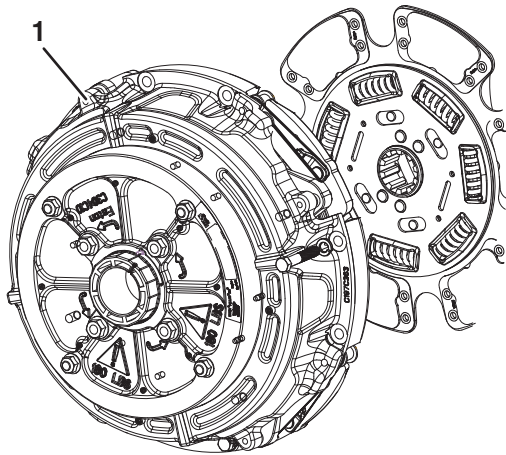

1. Clutch Housing Inspection Opening

2. Using a piece of 5/16" x 18 UNC x 3" threaded rod (jack screw), install two nuts on one end and lock them together. This will allow you to turn the jack screw in and out of the cover assembly.

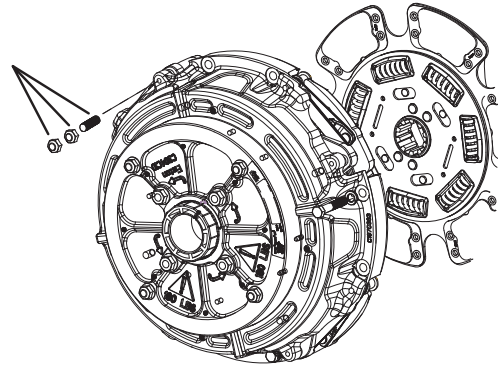

3. Install the jack screw into one of the four holes located adjacent to the clutch mounting bolts.

Note: This forces the pressure plate forward clamping the discs and holding them in place.

Caution: Do not over-tighten the jack screw. Tightening more than 9 lb-ft can cause permanent clutch damage.

Caution: Failure to remove the jack screw after the transmission is re-installed will result in severe clutch damage.

4. Remove the transmission, supporting its weight to prevent damage to the clutch discs.

5. Insert alignment shaft and clutch jack.

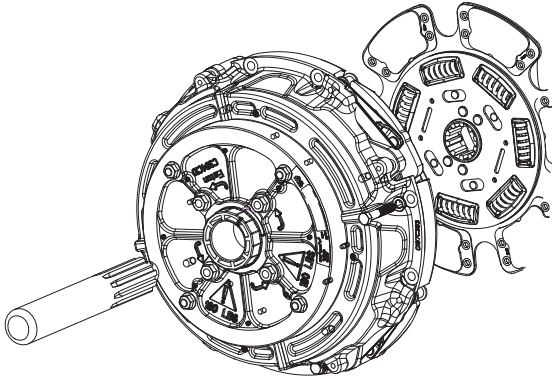

6. Remove the jack screw.
7. Unbolt the clutch from the flywheel and slide the clutch away from the flywheel.

Warning: An assembled clutch weighs approximately 182 lb (82 kg). Avoid the risk of injury. Use proper equipment when lifting a clutch.

Caution: When removing the clutch, the flywheel side disc can fall off of the alignment shaft, permanently damaging the driven disc.

8. Remove the old pilot bearing.

UltraShift® DM Heavy-Duty Clutch

Special Instructions

None

Clutch Installation

Measure Engine Flywheel Housing and Flywheel

! **Important:** For machining of the flywheel friction surface, contact the OEM engine manufacture for specifications.

! **Important:** Engine flywheel housing and flywheel must meet these specifications or it may result in premature clutch failure.

1. Remove and replace old pilot bearing per engine manufacturer instructions.
2. All gauge contact surfaces must be clean and dry. Clean flywheel surfaces of all grease, oil and rust preventatives. Failure to perform this function can affect the performance of the clutch.
3. Contact OEM engine manufacture for specific instructions for dial indication of the flywheel and flywheel housing.
4. Use a dial indicator to check the flywheel face runout.
 - a. Secure dial indicator base to flywheel housing face.
 - b. Put gauge finger in contact with flywheel face near the outer edge.
 - c. Rotate flywheel one revolution. Maximum runout is 0.008" (0.20 mm).
5. Use a dial indicator to check the pilot bearing bore runout.
 - a. Secure dial indicator base to flywheel housing face.
 - b. Position gauge finger so that it contacts pilot bearing bore.
 - c. Rotate flywheel one revolution. Maximum runout is 0.005" (0.13 mm).

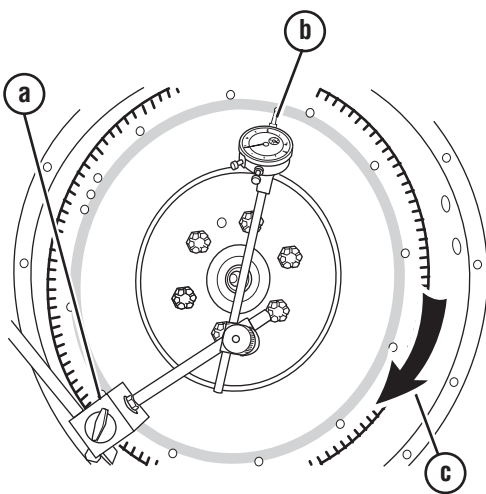
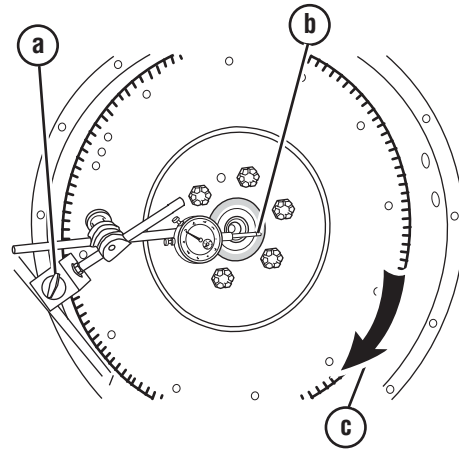

6. Use a dial indicator to check the flywheel housing I.D. runout.
 - a. Secure dial indicator base to crankshaft.
 - b. Put gauge finger against flywheel housing pilot I.D.
 - c. Rotate flywheel one revolution. Maximum runout is 0.012" (0.30 mm).

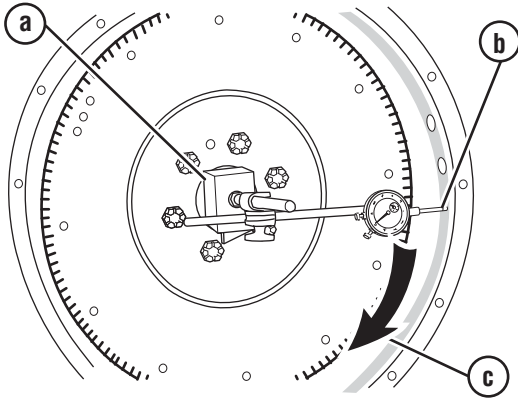

7. Use a dial indicator to check the flywheel housing face runout.
 - a. Secure dial indicator base to flywheel near the outer edge.
 - b. Put gauge finger in contact with face of flywheel housing.
 - c. Rotate flywheel one revolution. Maximum runout is 0.008" (0.20 mm).

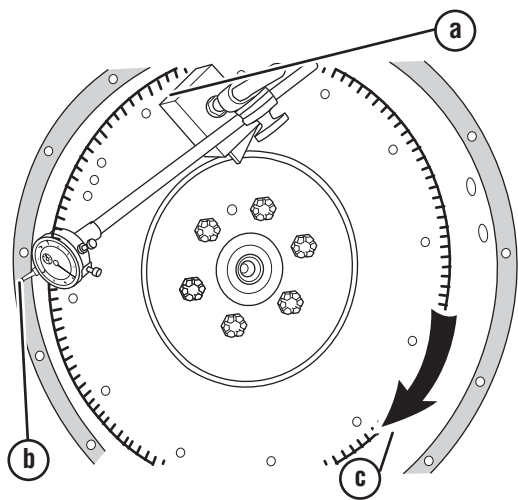

UltraShift® DM Heavy-Duty Clutch

Special Instructions

None

Install Clutch to Flywheel

Note: The required alignment tool, part number RR1009CL, can be ordered through K-Line at (800)-824-5546.

Warning: An assembled clutch weighs approximately 182 lb (82 kg). Avoid the risk of injury. Use proper equipment when lifting a clutch.

1. Install pilot bearing.

Note: See the Appendix for a list of recommended pilot bearings.

2. Measure the flywheel bore to verify that the damper will fit into the flywheel bore.

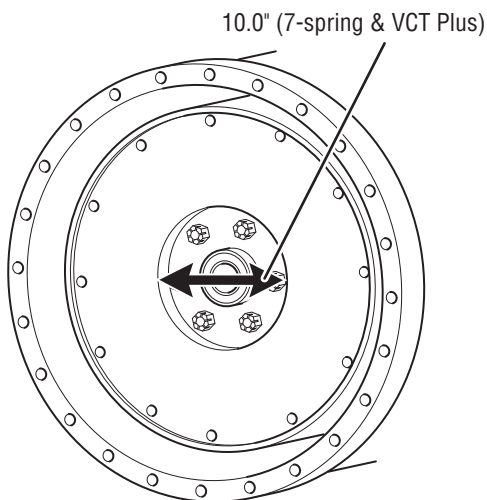

Special Tools

None

3. Insert aligning tool through DM Clutch and rear disc.

Warning: The intermediate plate is bolted to the cover assembly and the rear driven disc is held in place between the pressure plate and intermediate plate. Do not unbolt the intermediate plate from the cover assembly.

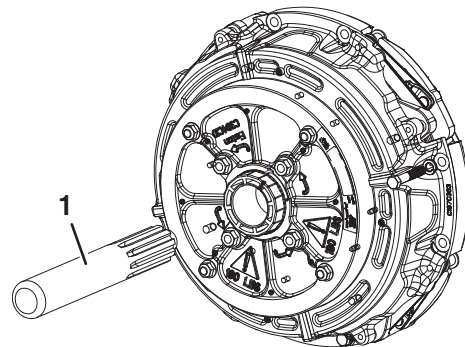

1. Aligning Tool

4. Install front disc onto aligning tool. Follow the orientation instructions on the disc.

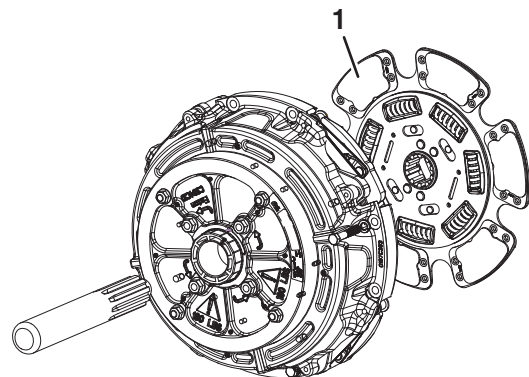

1. Front Disc

5. Install two 7/16" x 14 UNC x 5" studs into upper mounting holes. Using clutch jack or other lifting device, install assembled clutch.



Caution: Using the transmission to install the clutch can result in damage to the clutch assembly.

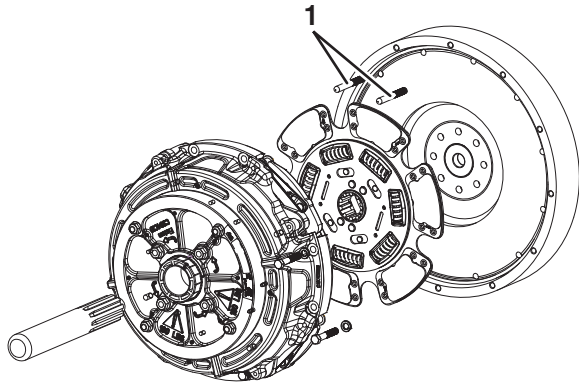

1. 7/16" x 14 UNC x 5" studs

6. Install lock washers and mounting bolts (7/16" x 14 UNC x 2-1/4" grade 5) finger tight. Replace studs with lock washers and bolts.

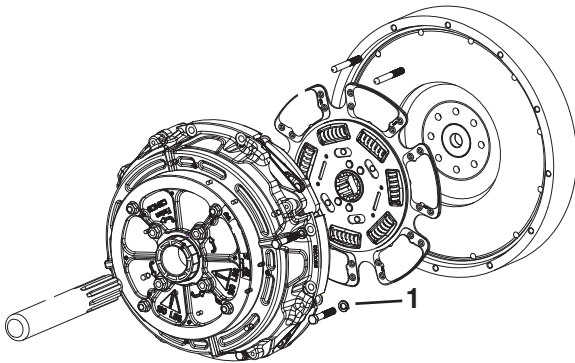

1. Lock Washers and Mounting Bolts

7. Progressively tighten mounting bolts in a crisscross pattern starting with the lower left bolt (1, 2, 3, 4, 5, 6, 7, 8). Torque to 40–50 lb-ft (54–68 N•m).



Caution: Failure to do this could result in improper piloting of the clutch to the flywheel and can result in a vibration or the clutch coming loose from the flywheel.

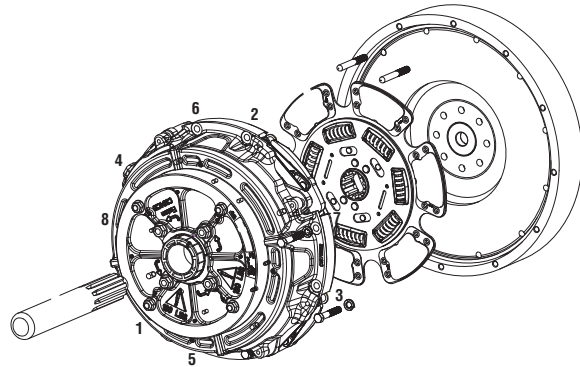

8. Option 1: Rotate the hub in the center of the cover counterclockwise will lock the disc in place. Option 2: Install the jack screw into one of the four holes located adjacent to the clutch mounting bolts. Be sure the hole chosen is at the 6 o'clock position to allow for removal after the transmission is installed.

Note: Using a piece of 5/16" x 18 UNC x 3" threaded rod (jack screw), install two nuts on one end and lock them together. This will allow you to turn the jack screw in and out of the cover assembly.

Caution: Do not overtighten the jack screw. Tightening more than 9 lb-ft will cause permanent clutch damage.

Note: Installing the jack screw into one of the four holes located adjacent to the clutch mounting bolts forces the pressure plate, forward clamping the discs and holding them in place.

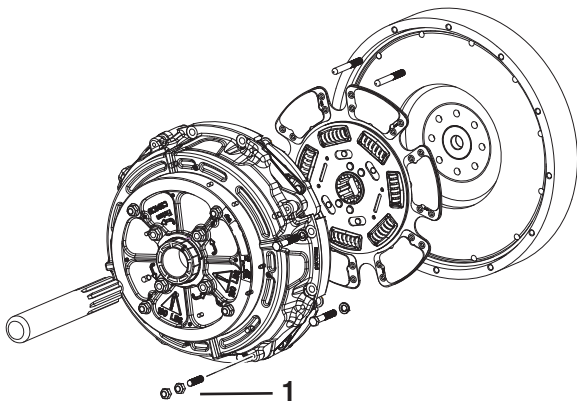

1. 5/16" x 18 UNC x 3" Jack Screws

9. Remove the aligning tool.

Transmission

1. Inspect the transmission for wear. Replace any worn components.

2. Inspect the input shaft splines. Any wear on the splines will prevent the driven discs from sliding freely, causing poor clutch release (clutch drag). Slide discs full length of shaft to check for twisted shaft splines.

Important: Do not add lube (anti-seize or grease) to the input shaft splines. The disc must be free to slide.

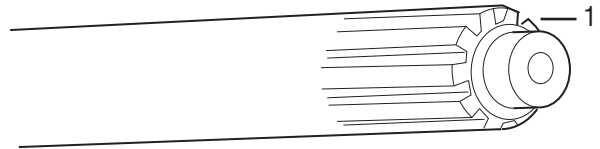

1. Input Shaft Splines

3. Inspect the input shaft spigot. Wear will not provide proper interface with the inner race of the pilot bearing. This can result in damage to the clutch or the pilot bearing.

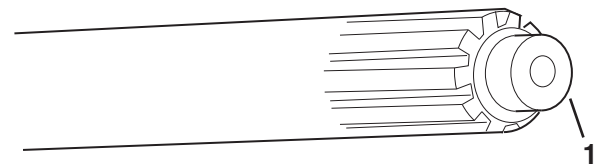

1. Input Shaft Spigot

4. Fasten transmission to flywheel housing.
5. Position the transmission so it is square to and aligned with the engine.

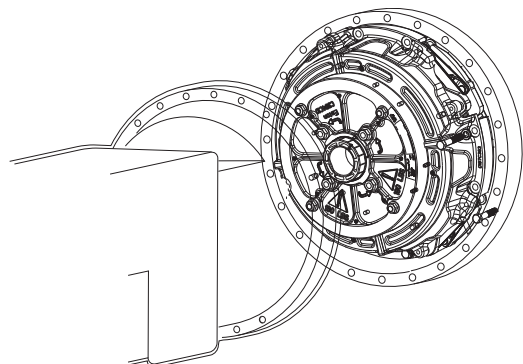

6. Mesh splines by moving the transmission forward and rotating the input shaft. Do not use excessive force. Do not let the transmission hang unsupported in the discs.

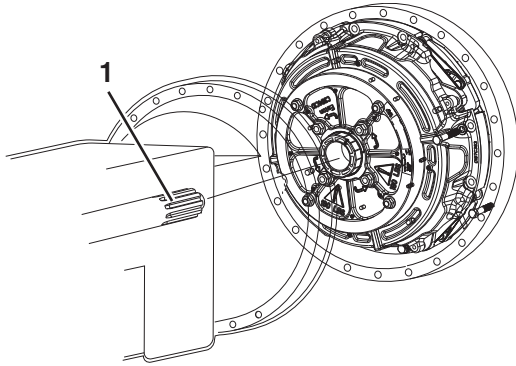

1. Input Shaft

7. Install mounting bolts and torque to OEM specs.

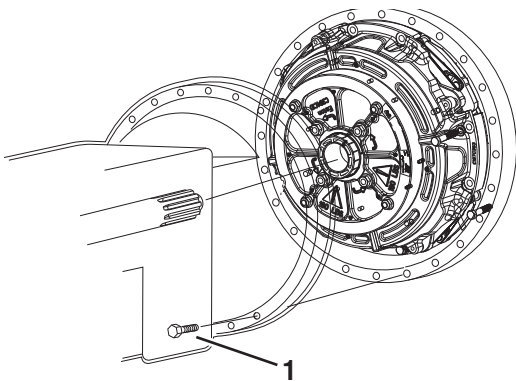

1. Mounting Bolt

8. If a jack screw was installed to hold the driven disc in position, remove the jack screw.

Warning: Failure to remove the jack screw after the transmission is re-installed will result in severe clutch damage.

9. Reconnect UltraShift wiring harness.

Warning: Do not let the transmission drop or hang unsupported in the driven discs. This can cause the discs to become distorted and the clutch to not release.

Caution: Do not use excessive force. If it does not enter freely, investigate the cause of problem and make any necessary changes.

UltraShift® DM Heavy-Duty Clutch

Special Instructions

None

Special Tools

None

Clutch Recalibration

1. Turn key on.
2. Verify a solid “N” is on the gear display.

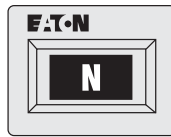

3. Start engine.
4. Increase engine RPM above 1500. This will unlock the clutch.

Note: Failure to do this will set a clutch disengagement code and the transmission will not go into gear.

Note: Programmable VSS Tamper Resistance options or other artificial engine speed limits which prevent reaching the required 1500 RPM may prevent proper disengagement of the clutch-locking device after initial installation. These options may need to be disabled until after the clutch-locking device is disengaged.

Note: If ServiceRanger is available, proceed to **Step 12**.

5. Start with the system powered down, the vehicle stationary and the engine not running.
6. Key on and allow the system to completely power up but do not start the engine.
7. Select “LOW” mode on the shift controller (UltraShift system will begin to emit an audible tone).
8. Select an up shift once (UltraShift gear display will display a “0” with down arrows and discontinue the tone indicating “Special Functions” mode is activated).

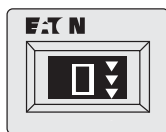

9. Once in Special Functions mode, select one additional up shift (UltraShift gear display will display a “1” with up arrows indicating UltraShift Touch Point Reset is selected).

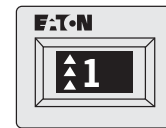

10. After the “1” is displayed, depress the throttle pedal to the floor and hold for 3–5 seconds (the gear display will change back to a “0” with down arrows indicating the routine has been successfully completed).

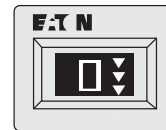

11. Key off or select any mode and the UltraShift system returns to normal operation.
12. Save clutch data / recalibrate clutch with Service Ranger.

Gen 2

1. Using ServiceRanger, select the “Advanced Product Functions” button located on the main menu.
2. Select “Eaton AutoShift Gen 2” from the product selection screen.

Note: This screen will only appear if the vehicle is equipped with more than one supported Roadranger product.

3. Select “Clutch Data” from the “Advanced Product Functions” screen.
4. Save the clutch data by selecting the “Save Abuse Info to a File” button.

Note: Use the truck VIN as the file name. The data file will be saved to the ServiceRanger folder in the Clutch Data sub-folder (e.g., C:\Serviceranger\Clutch Data).

5. Reset clutch abuse info by selecting the “Reset Clutch Abuse Info” button.
6. Recalibrate the new clutch by selecting the “Calibrate Clutch” button.

Note: Failure to calibrate a newly installed clutch may result in some initial harsh vehicle launches, as the system is required to manually recalibrate.

Gen 3

1. Using ServiceRanger, select “Advanced Product Function” button.
2. Select “UltraShift Transmission Model (Gen 3)” from menu tree in the upper left.
3. Select the “VPA/SnapShot Utility” and launch the function.
4. Read the APF description and select “Next”.
5. Enter the vehicle info and select “Next”.
6. Select “VPA” from the drop-down “Data Source” field.
7. Enter an output file name and location using the Browse button or use default filename and location shown.

Note: If the default filename and location is used, the VPA data file will be saved to the ServiceRangerData folder in the VPA sub-folder on the C:\drive.

8. Select the “Start Transfer” button to download data from transmission controller and then select “Next”.
9. The output file can now be viewed, select “Finish”.
10. Select “Clear Clutch Data” button to clear data from transmission controller.
11. If successful, proceed to next step; if unsuccessful, exit function and re-enter.
12. Select the “Calibrate Clutch” button to calibrate new clutch and the select “Finish” when complete.

ECA Clutch

Special Instructions

None

Special Tools

None

Clutch Removal

Caution: Note the position of the wear indicating tab on the clutch. If the tab is near the “REPLACE” position, the clutch should be replaced.

Note: The clutch release yoke fingers must be positioned so they clear the release bearing housing when removing and installing the transmission.

- **Preferred method:** Move the release yoke to the service position via the ServiceRanger Advanced Product Functions.
- **Secondary method:** Remove the ECA prior to removing the transmission and then manipulate the fingers by hand.

1. Move ECA Clutch to service position.

Caution: Ensure that hands are not inside the clutch housing while opening or closing the clutch.

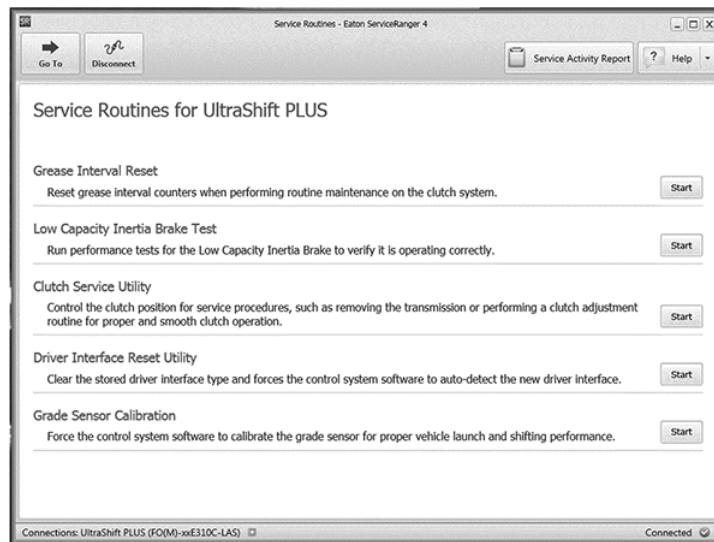

2. Turn ignition switch to on.

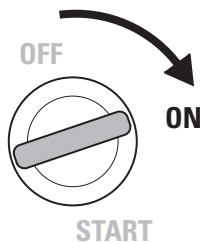

3. Plug 9-Way connector into dash port.

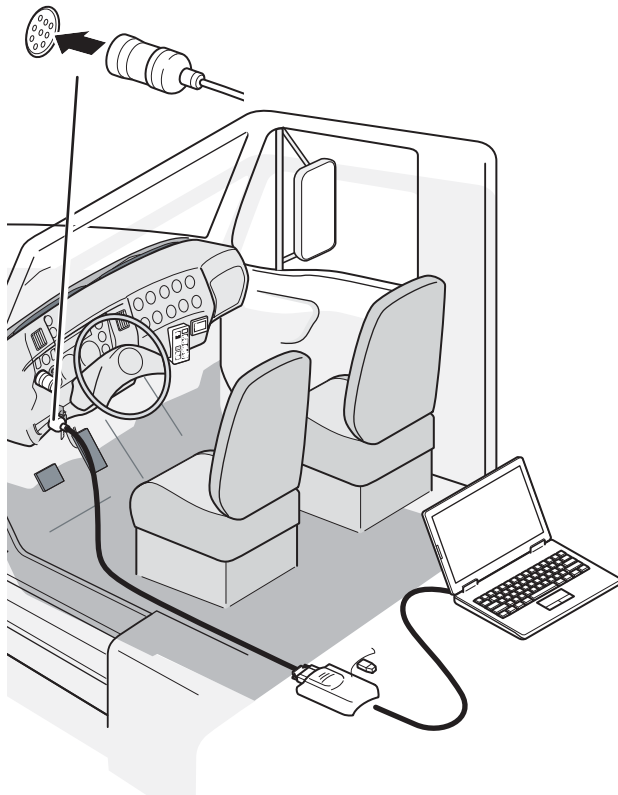

4. Click on ServiceRanger icon to launch program.
5. Open and expand the Advanced Product Functions tree.
6. Click on transmission.

Note: Advanced Product Functions appear.

7. Click on ECA Clutch Service.

Caution: Ensure that hands are not inside the clutch housing while opening or closing the clutch.

8. Choose Clutch Position tab.
9. Click Move to Service Position button.
10. Confirm Positive results.
11. Remove the transmission, supporting its weight to prevent damage to the bearing and discs.

12. Locate the four shipping bolts (7/16" x 14 x 1 3/4" UNC, hex head). Install them in the four cover holes hand tight then turn one full turn.



Important: Failure to install the four shipping bolts prior to the removal of the clutch will result in clutch damage and void the clutch warranty.

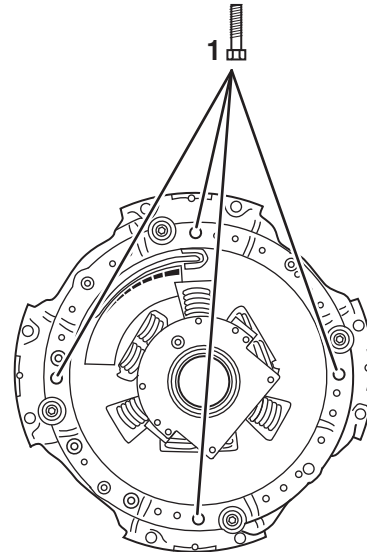

1. Shipping Bolts, four 7/16" x 14 x 1-3/4" UNC

13. Remove two of the top mounting bolts and install two 7/16" x 14 UNC x 5" studs. Then remove the remaining six mounting bolts.



Warning: An assembled clutch weighs approximately 180 lb (81 kg). Use proper equipment to remove the ECA clutch from the flywheel.

ECA Clutch

Special Instructions

None

Clutch Installation

! **Important:** For machining of the flywheel friction surface, contact the OEM engine manufacture for specifications.

Measure Engine Flywheel Housing and Flywheel

! **Important:** Engine flywheel housing and flywheel must meet these specifications or it may result in premature clutch failure.

1. Remove and replace old pilot bearing per engine manufacturer instructions.
2. All gauge contact surfaces must be clean and dry. Clean flywheel surfaces of all grease, oil and rust preventatives. Failure to perform this function can affect the performance of the clutch.
3. Contact OEM engine manufacture for specific instructions for dial indication of the flywheel and flywheel housing.
4. Use a dial indicator to check the flywheel face runout.
 - a. Secure dial indicator base to flywheel housing face.
 - b. Put gauge finger in contact with flywheel face near the outer edge.
 - c. Rotate flywheel one revolution. Maximum runout is 0.008" (0.20 mm).
5. Use a dial indicator to check the pilot bearing bore runout.
 - a. Secure dial indicator base to flywheel housing face.
 - b. Position gauge finger so that it contacts pilot bearing bore.
 - c. Rotate flywheel one revolution. Maximum runout is 0.005" (0.13 mm).

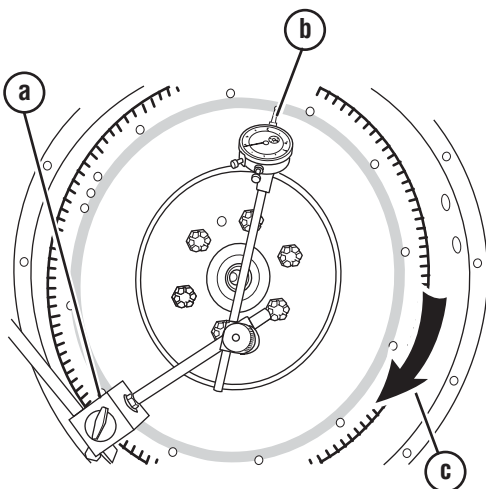
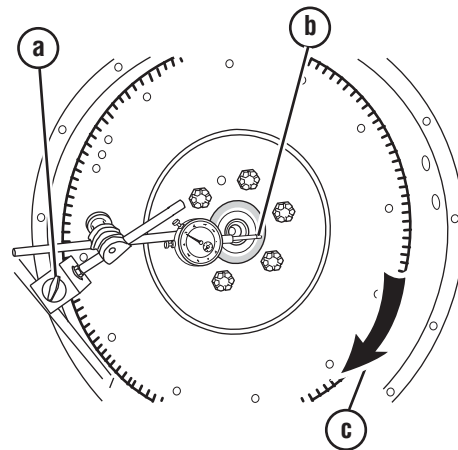

6. Use a dial indicator to check the flywheel housing I.D. runout.
 - a. Secure dial indicator base to crankshaft.
 - b. Put gauge finger against flywheel housing pilot I.D.
 - c. Rotate flywheel one revolution. Maximum runout is 0.012" (0.30 mm).

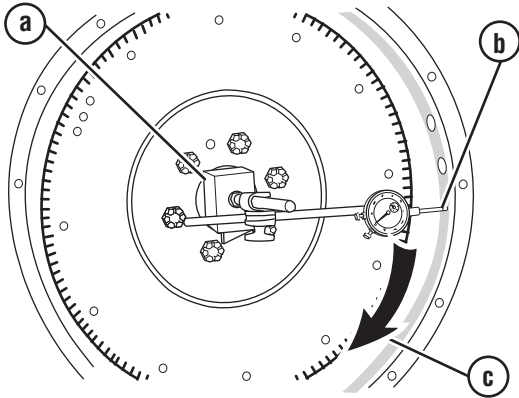

7. Use a dial indicator to check the flywheel housing face runout.
 - a. Secure dial indicator base to flywheel near the outer edge.
 - b. Put gauge finger in contact with face of flywheel housing.
 - c. Rotate flywheel one revolution. Maximum runout is 0.008" (0.20 mm).

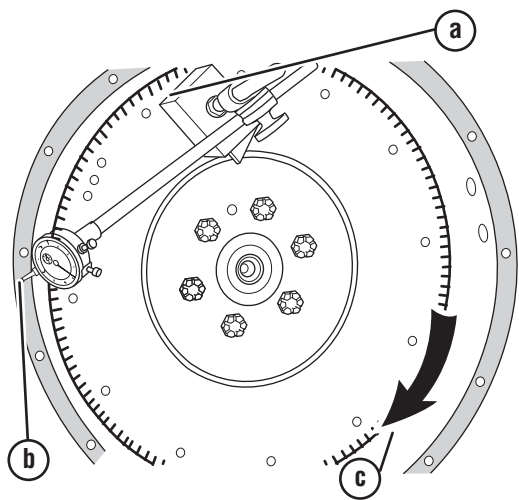

ECA Clutch

Special Instructions

None

Special Tools

None

Install Clutch to Flywheel

Note: The clutch release yoke fingers must be positioned so they clear the release bearing housing when installing the transmission.

Warning: An assembled clutch weighs about 180 lb (68 kg). Avoid the risk of injury. Use proper equipment when lifting a clutch.

Warning: Do not unbolt the intermediate plate from the cover assembly.

Warning: Do not unbolt the intermediate plate from the cover assembly.

1. Insert aligning tool through bearing.

Note: The ECA Clutch alignment tool is a 14-tooth shaft and is 1-3/4" longer than the standard shaft.

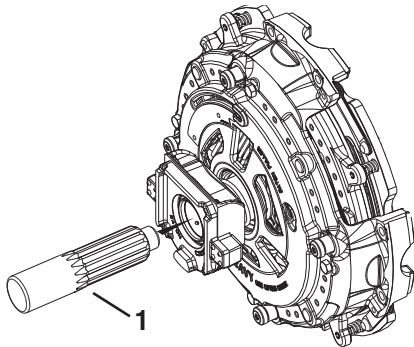

1. Aligning Tool

2. Install second disc onto aligning tool. Follow the orientation instructions on the disc.

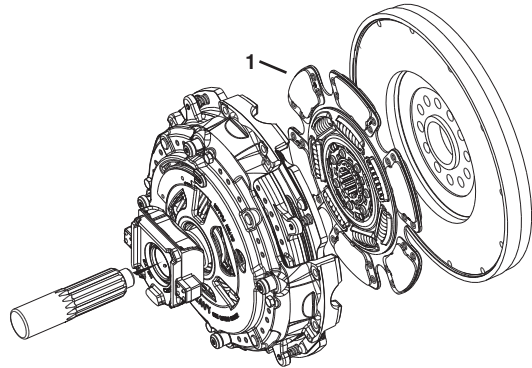

1. Second Disc

3. Install two 7/6" x 14 UNC x 5" studs into upper mounting holes. Install assembled clutch.

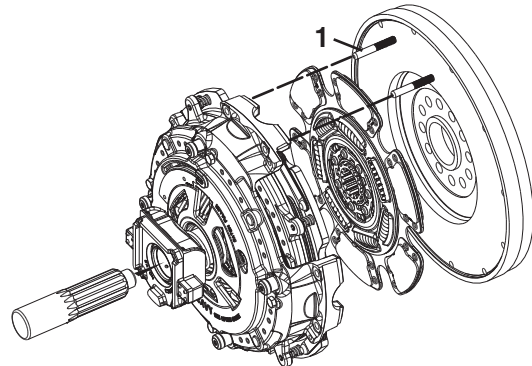

1. 7/6" x 14 UNC x 5" Studs

- Slide the clutch assembly over the guide studs and install six lock washers and mounting bolts (7/16" x 14 UNC x 2 1/4" grade 5) finger tight. Replace studs with remaining two lock washers and bolts.

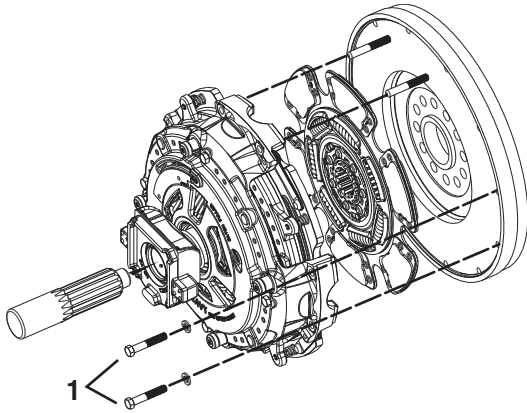

1. Mounting Bolts

- Progressively tighten mounting bolts in a crisscross pattern starting with the lower left bolt (1, 2, 3, 4, 5, 6, 7, 8). Torque to 40–50 lb-ft (54–68 Nm).



Caution: Failure to do this could result in improper piloting of the clutch to the flywheel and can result in a vibration, or worse, the clutch coming loose from the flywheel

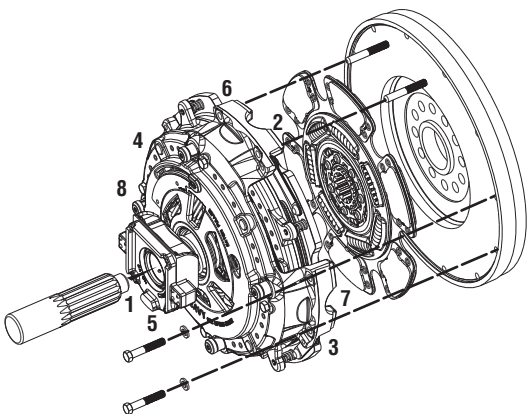

- Remove the four yellow shipping bolts in an even 1/4 turn crisscross pattern.

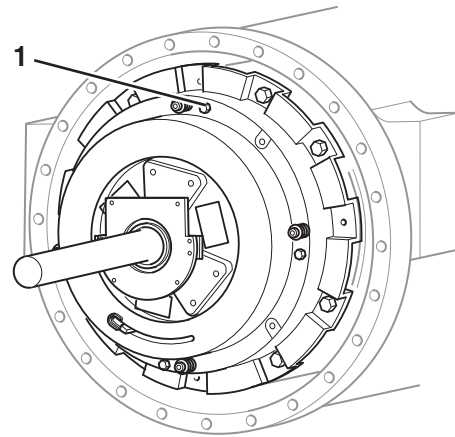

1. Shipping Bolt

- Remove aligning tool.

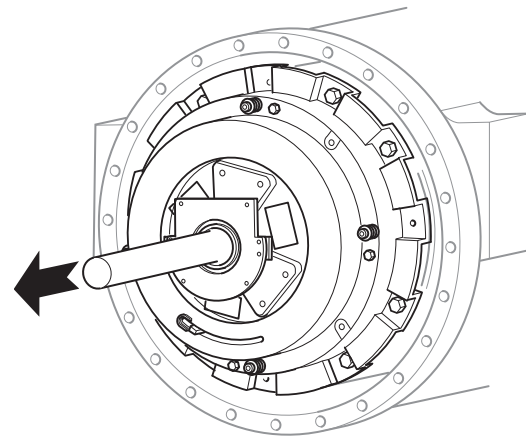

- Position the release bearing so the orientation of the lube fitting is in the 4 o'clock position.

Note: Following transmission and ECA installation perform clutch adjustment.

Low Capacity Inertia Brake (LCIB)

-

Transmission

Inspect Transmission for Wear

- Replace any worn components.

2. Inspect the input shaft. Wear (roughness) can reduce sleeve bushing life and cause it to become dislodged.
3. Inspect the cross shaft and bushings. Excessive wear at these points can cause side loading on the sleeve bushing, bushing failures and yoke bridge contact with the clutch in the release/open position.
4. Inspect the input shaft splines. Any wear on the splines will prevent the driven discs from sliding freely, causing poor clutch release (clutch drag). Slide discs full length of shaft to check for twisted shaft splines.
5. Inspect the input shaft spigot. Wear will not provide proper interface with the inner race of the pilot bearing. This can result in damage to the clutch or the pilot bearing.
6. Inspect the Low Capacity Inertia Brake (LCIB). Eaton requires that you replace the LCIB when replacing the clutch. See Appendix A for LCIB removal and installation instruction.
7. Inspect the release yoke. Worn, missing or loose rollers can cause bushing wear and yoke interference when the Electronic Clutch Actuator is at the released position.

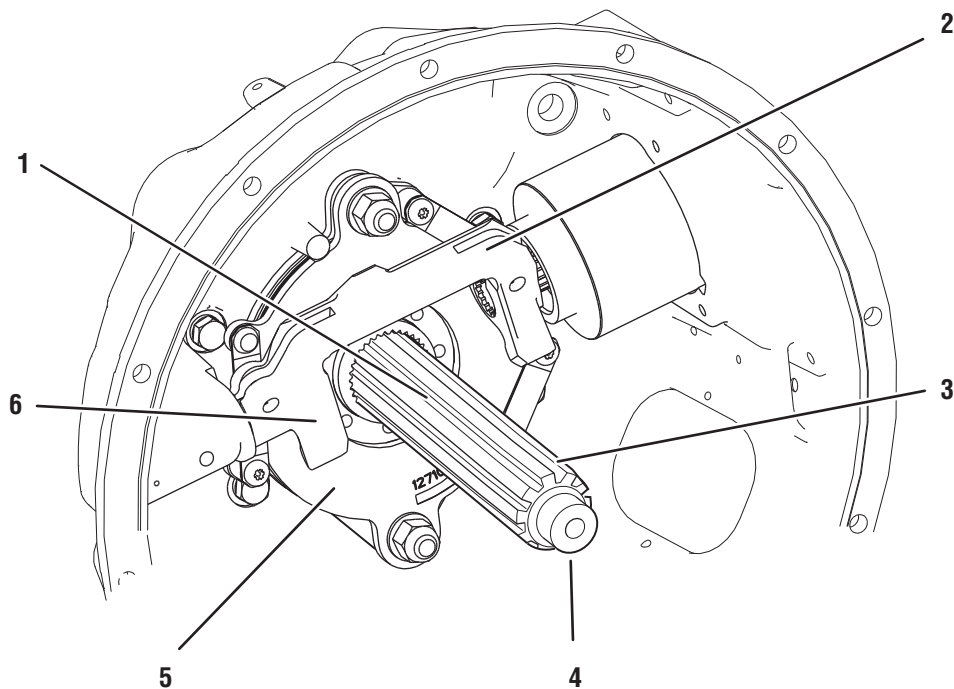

1. Input Shaft
2. Cross Shaft and Bushings
3. Input Shaft Splines

4. Input Shaft Spigot
5. Low Capacity Inertia Brake (LCIB)
6. Release Yoke

Fasten Transmission to Flywheel Housing

Note: If the ECA has been removed, ensure the yoke fingers remain in the up position. Use the opening vacated by the ECA to rotate the yoke in the up position just before the transmission is going to be aligned.

1. Be sure new LCIB has been installed.

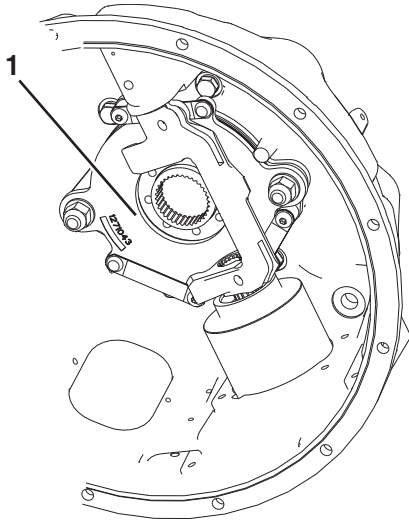

1. Low Capacity Inertia Brake

2. Make sure that the yoke fingers are rolled and remain in the up position until they are over the release bearing housing.

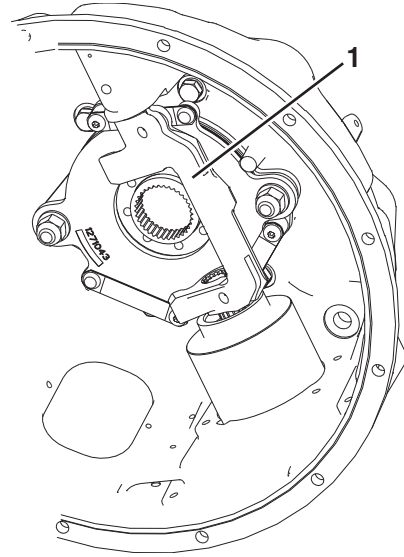

1. Yoke Finger

3. Position transmission so it is square to and aligned with engine.

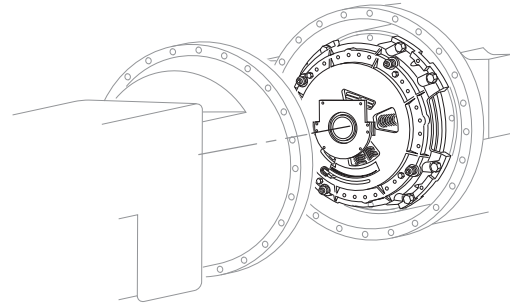

4. Mesh splines by moving transmission forward and rotating the input shaft. Do not use excessive force.

 **Warning:** Do not let the transmission hang unsupported in the discs.

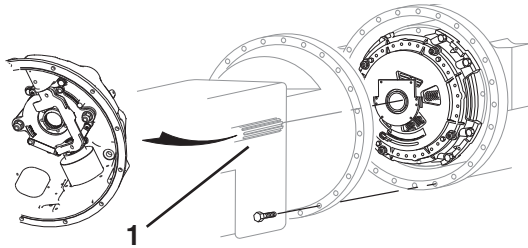

1. Input Shaft

5. Install mounting bolts and torque to OEM specs.
6. Through the hand hole cover, install lube tube to the release bearing.

Note: Following transmission and ECA installation, perform clutch adjustment.

Electronic Clutch Actuator (ECA)

NEED INFORMATION FROM SERVICE BULLETIN

- 1.

ECA Clutch

Special Instructions

None

Special Tools

None

Clutch Lubrication

! **Important:** All clutches use a lithium complex grease with a minimum of 325°F (163°C) operating range meeting NLGI Grade 2 or 3 specs.

! **Caution:** Failure to properly lubricate the bearing/bushing will result in bearing and sleeve failures.

! **Important:** Do not add lube (anti-seize or grease) to the input shaft splines. The disc must be free to slide.

Note: Zerk fittings are labeled RS (Release Bearing) and CS (Cross Shaft) on the clutch housing case.

1. Open the inspection cover and verify the cross-shaft and release bearing lube tubes are properly attached and functional.

Note: Failed lube lines will prevent grease from reaching the release bearing causing premature clutch release bearing failure.

2. Apply grease through the release bearing lube tube and continue to apply lube to cause enough grease to purge out of the release bearing housing and onto the

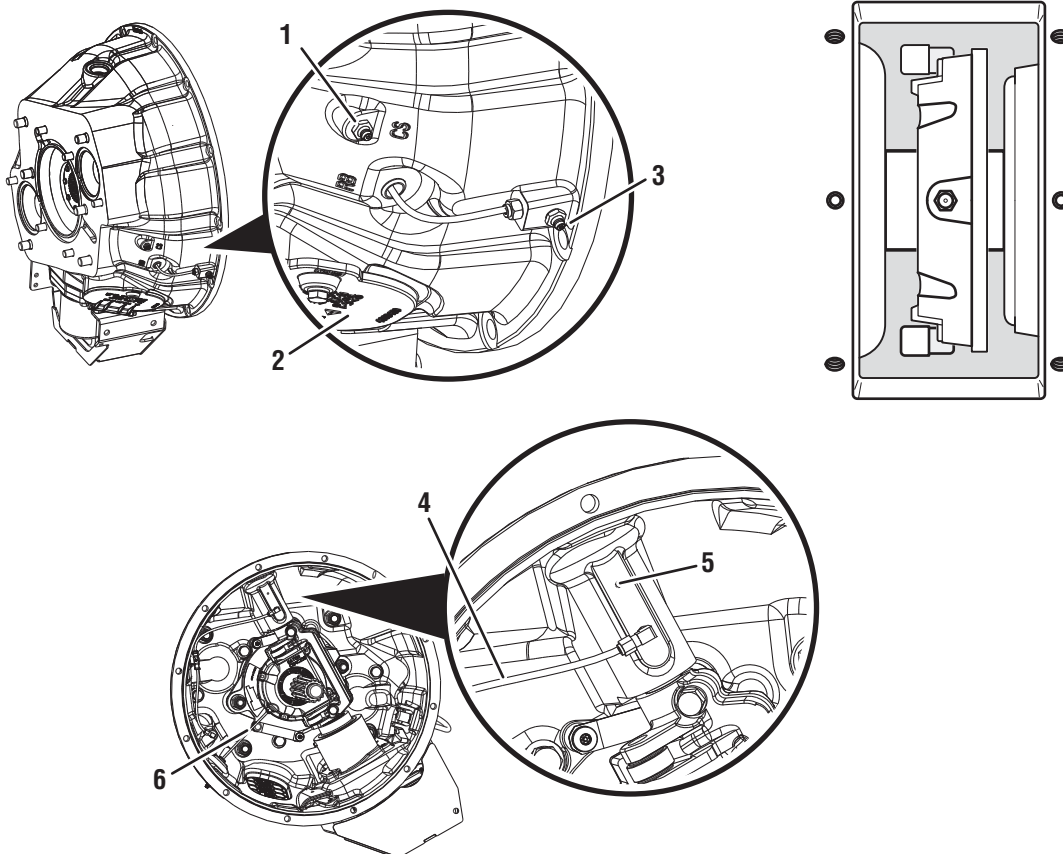

1. Cross Shaft Zerk
2. Inspection Cover
3. Release Bearing Zerk

4. Inspection Cover
5. Cross Shaft Bushing Weep Hole
6. Release Bearing Lube Tube

ECA Clutch

Special Instructions

None

Special Tools

None

Clutch Adjustment

A clutch adjustment should always be performed after a clutch replacement. This command signals the ECA to actuate the clutch in order to reset to the default clutch position in the transmission ECU.

1. Turn ignition switch to on.

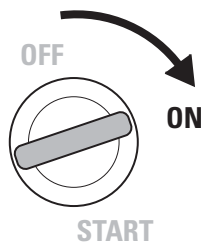

2. Plug 9-pin connector into dash port.

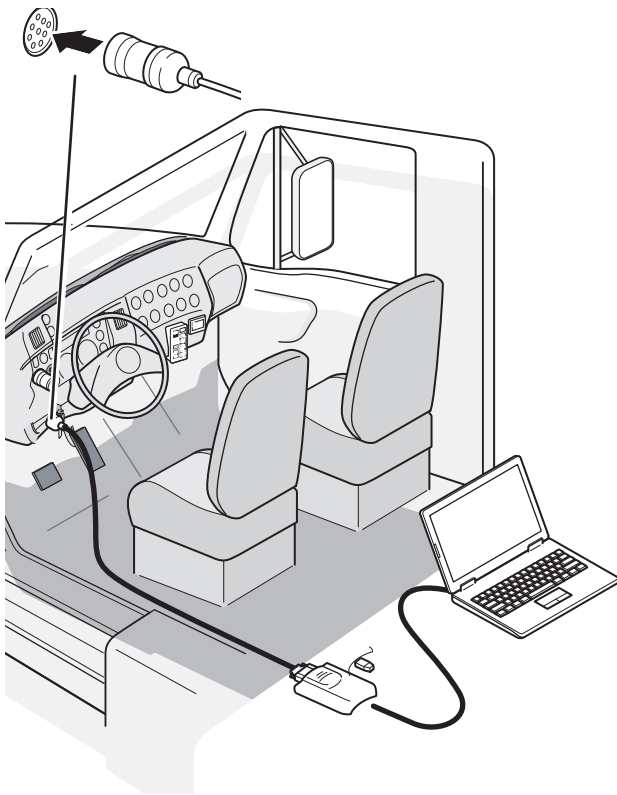

3. Click on ServiceRanger icon to launch program.
4. Open and expand the Advanced Product Functions tree.
5. Click on transmission.

Note: Advanced Product Functions appear.

6. Click on ECA Clutch Service.

Caution: Ensure that hands are not inside the clutch housing while opening or closing the clutch.

7. Choose Clutch Position tab.
8. Click on Request Clutch Adjustment.

ECA Clutch

Special Instructions

None

Grease Interval Count Reset

The Heavy-Duty UltraShift *PLUS* has an optional prognostic feature that notifies the operator when the Clutch Release Bearing needs greasing. This feature can be enabled or disabled via ServiceRanger.

1. At the appropriate grease interval and shortly after each engine start, "GI" will momentarily appear in the gear display, along with an audible tone. This will continue to occur at each engine start until clutch service has been completed.

Note: "GI" stands for grease interval and may be misread as "G1" on gear display.

2. The operator can choose to follow this Automated Lube Schedule or the published lube guidelines in the Lubrication Manual TCMT0021. When enabled, it is highly important to reset the Grease Interval Count every time the release bearing is greased.
3. The Grease Interval Count can be reset via ServiceRanger or Operator Triggered Special Function.

⚠ Caution: Ensure that hands are not inside the clutch housing while opening or closing the clutch.

4. Turn ignition switch to on.

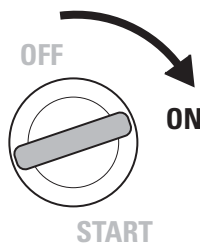

Special Tools

None

5. Plug 9-pin connector into dash port.

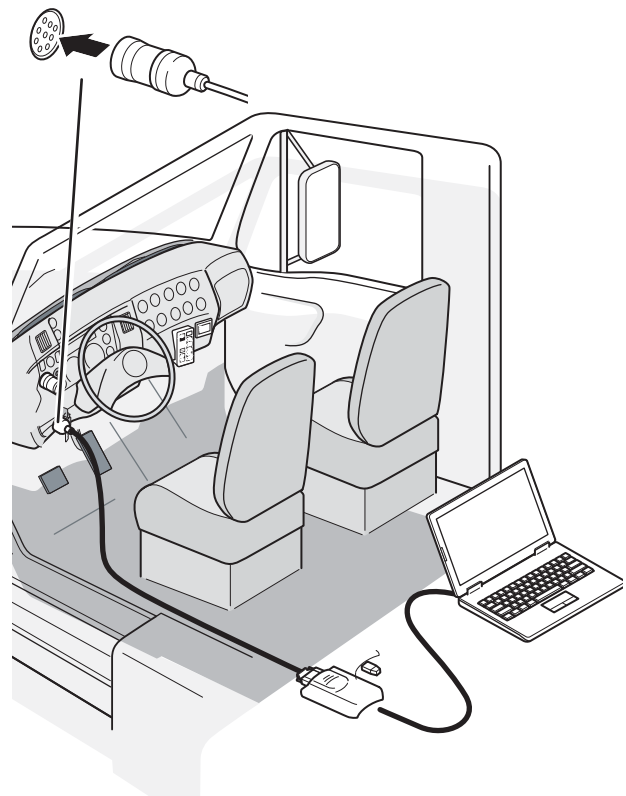

6. Click on ServiceRanger icon to launch program.
 7. Open and expand the Advanced Product Functions tree.
 8. Click on transmission.
- Note:** Advanced Product Functions appear.
9. Click on ECA Clutch Service.

⚠ Caution: Ensure that hands are not inside the clutch housing while opening or closing the clutch.

10. Choose Clutch Position tab.
11. Click on Request Clutch Adjustment.

Operator Triggered

1. From the off position, turn ignition to on without cranking the engine.

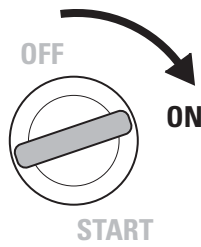

2. Select low mode on the shift device.

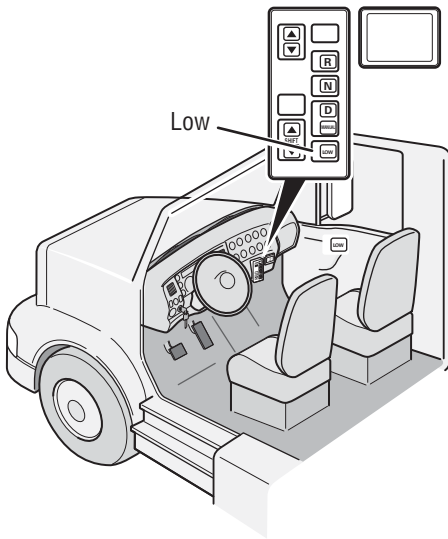

3. Press the manual up-shift button until the gear display shows "3".

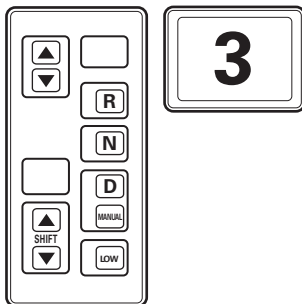

4. Press Accelerator to the floor. Gear display will show a down arrow.

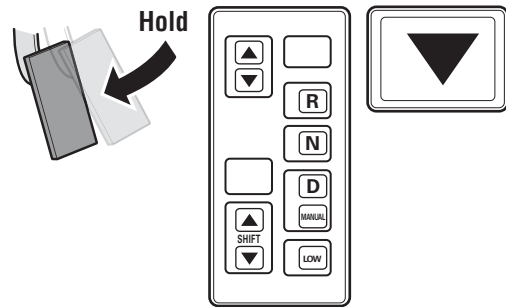

5. Release the accelerator. Gear display will show a "0".

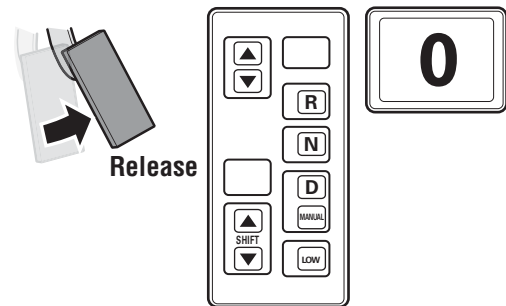

6. Select neutral and turn ignition to off in order to save the reset.

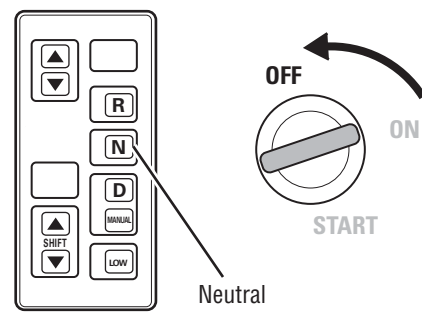

ECA Clutch

Special Instructions

None

Special Tools

None

Clutch Resetting Procedures

1. Measure distance between release bearing and Low Capacity Inertia Brake (LCIB):
 - It is necessary to compress the LCIB to a solid condition prior to measuring the distance between the LCIB and the release bearing. A screw driver can be used to compress the LCIB.
 - With the LCIB compressed, proceed in measuring the distance between the release bearing and LCIB. If the measurement is not between 0.490" and 0.560" reset clutch. Go to Step 2.

Correct Distance =
0.490" – 0.560"

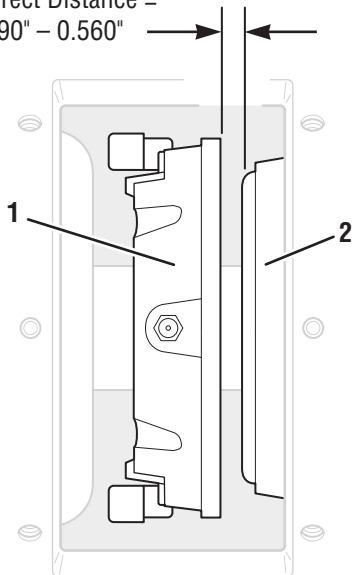

1. Release Bearing
2. Low Capacity Inertia Brake

2. Eaton ServiceRanger Diagnostic Software is needed to command the ECA to open the clutch.

Note: Keep the ECA Clutch Service Utility open. It will be used again during this process.

3. Open the ECA clutch.

Caution: Ensure that hands are not inside the clutch housing while opening or closing the clutch.

4. Turn ignition switch to on.

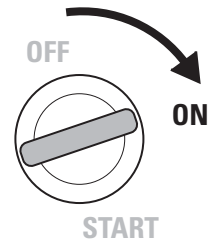

5. Plug 9-pin connector into dash port.

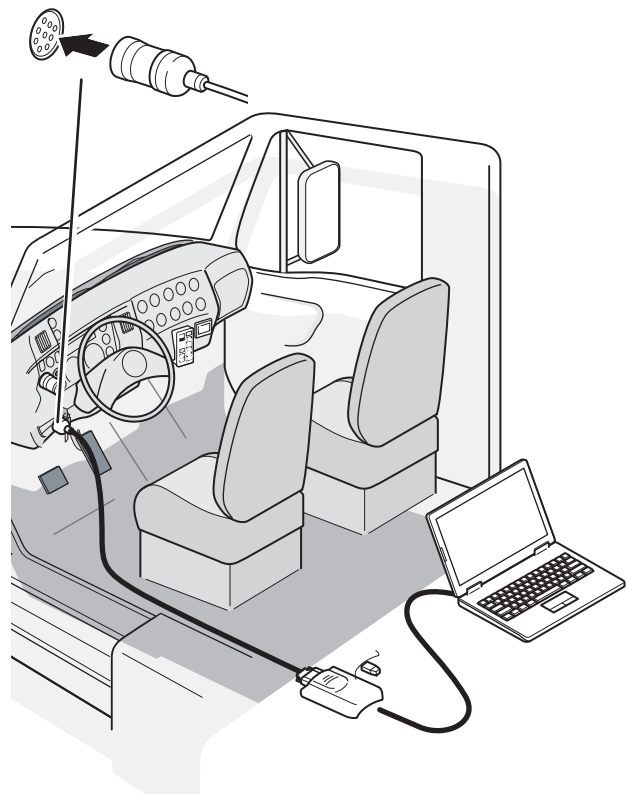

6. Click on ServiceRanger icon to launch program.
7. Open and expand the Advanced Product Functions tree.

8. Click on transmission.

Note: Advanced Product Functions appear.

9. Click on ECA Clutch Service.

Caution: Ensure that hands are not inside the clutch housing while opening or closing the clutch.

10. Choose Clutch Position tab.

11. Click on Request Clutch Adjustment.

12. Turn ignition switch to off.

13. Position Reset Tool:

- Through the access panel.
- Under the release bearing.
- With threaded bolt in cam slot.

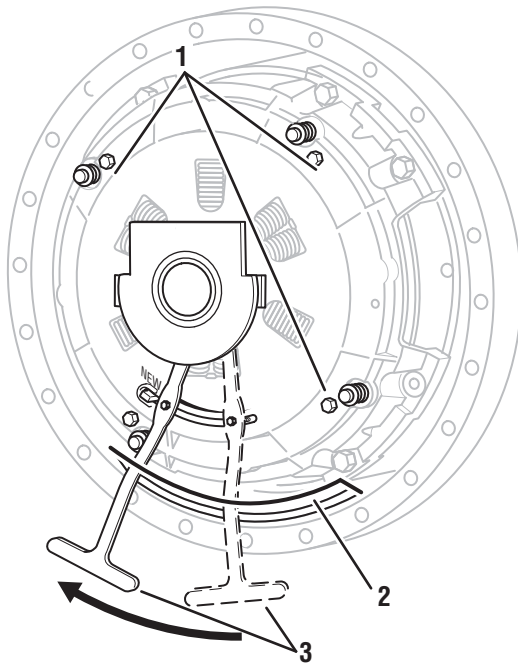

1. Shipping Bolts
2. Access Panel
3. Position Reset Tool

14. Use tool to move cam to the new position.

Note: If the cam does not move, loosen transmission and install 1/2" spacers between clutch housing and engine housing to increase stroke:

- With spacers in place, follow **Steps 2 through 15** in this procedure.
- Remove spacers and torque transmission mounting bolts.
- Continue process starting at **Step 16**.

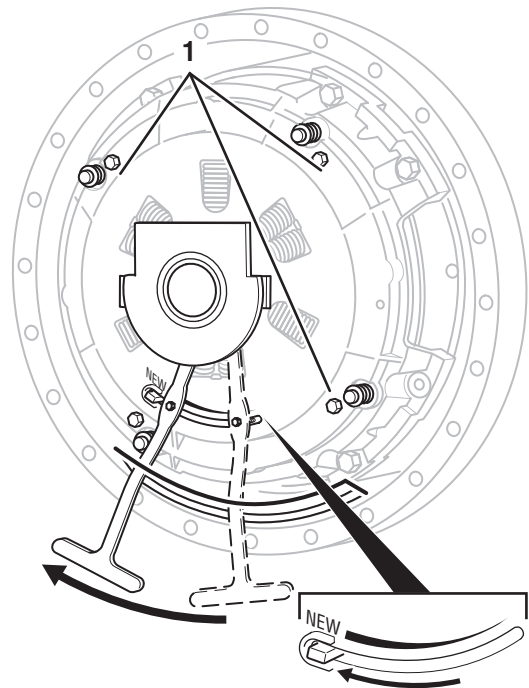

1. Shipping Bolts

15. Without cranking the engine, close the clutch by switching the ignition to on.

Caution: Ensure that hands are not inside the clutch housing when opening or closing the clutch.

16. Install and tighten the four shipping bolts (7/16" x 14 x 1-3/4 UNC) to remove gap between sleeve and pin.

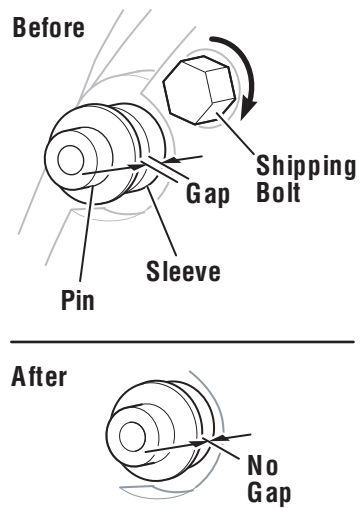

17. Remove the four shipping bolts in a crisscross pattern a 1/4 turn at a time.
18. In the ECA Clutch Service utility, select the Request Clutch Adjustment command, and follow ServiceRanger instructions.
Note: The Request Clutch Adjustment command will automatically initiate the ECA to open and close the clutch, causing a clutch adjustment to take place.
19. Verify reset. Go to Step 1.

Low Capacity Inertia Brake Wear Life Measurement

Special Instructions

None

Special Tools

None

General Information

Transmission Removed

1. Compress down the Low Capacity Inertia Brake (LCIB) by hand.
2. Using a shim or a feeler/thickness gauge, measure the gap between the mounting stud nut/washer and the front of the LCIB, caused when the LCIB is compressed.
3. Using calipers, measure the thickness of the feeler gauge:
 - If the gap between mounting stud nut/washer and front of LCIB is 0.140" or less, then there is approximately 50% wear life remaining.
 - If the gap between mounting stud and front of LCIB is 0.220" or greater, then LCIB should be replaced soon.

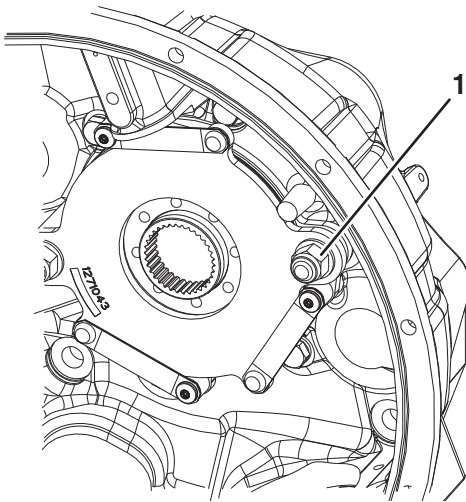

1. Mounting Stud Nut/Washer

Transmission in Chassis

1. Open inspection cover.
2. Through the inspection cover opening, lightly compress down the Low Capacity Inertia Brake (LCIB) using an appropriate tool to avoid damaging the LCIB.
3. With your other hand, use a shim or a feeler gauge to measure the gap between the mounting stud nut/washer and the front of the LCIB, caused when the LCIB is compressed.
4. Using calipers, measure the thickness of the feeler gauge:
 - If the gap between mounting stud nut/washer and front of LCIB is 0.140" or less, then there is approximately 50% wear life remaining.
 - If the gap between mounting stud and front of LCIB is 0.220" or greater, then LCIB should be replaced soon.
5. After measurements have been taken, close inspection cover.

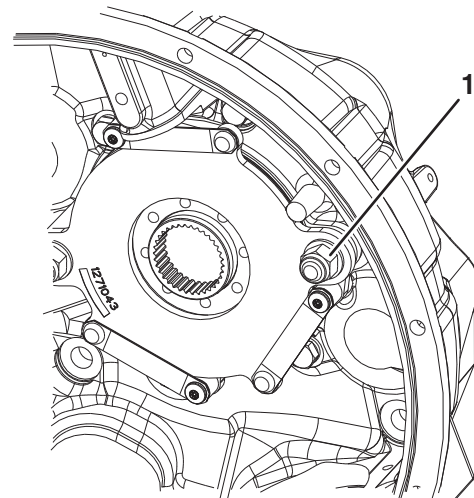

1. Mounting Stud Nut/Washer

Hydraulic Linkage

Special Instructions

None

Special Tools

None

General Information

Verify Linkage System Stroke

1. Measure the release bearing position with the pedal up and pedal down to verify bearing travel.
2. The hydraulic linkage should allow for a minimum of 0.600" of yoke finger movement: 0.500"–0.560" for clutch release plus additional movement for clutch brake squeeze.
3. If the system does not provide enough movement of the release bearing, the clutch will not adjust and the bearing will move away from the transmission and lose clutch brake squeeze.
4. If the system is operational, clutch replacement may be necessary. If replacing the clutch, you must adhere to OEM warranty guidelines prior to claim disposition.

Master Cylinder

1. Master cylinder may be mounted at any angle ranging from vertical to horizontal, depending on application.

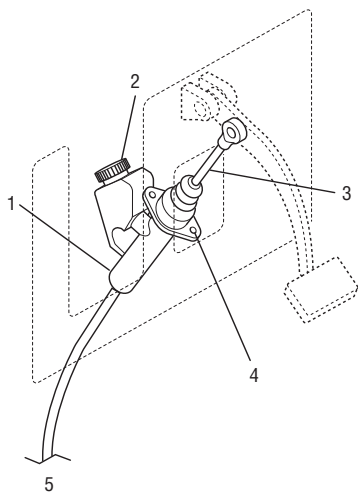

- 1 - Master cylinder
- 2 - Reservoir
- 3 - Pushrod
- 4 - Bolts (2), M8 x 1.25 mm (torque 20-25 N•m)
- 5 - To booster or slave

2. Ensure there is constant rise in hose from master cylinder to the remote reservoir.

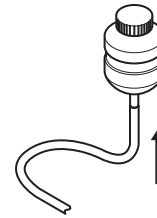

3. Free play in a hydraulic release system is required to ensure that the piston in the master cylinder returns past the port in the master cylinder. This will allow residual fluid in the system to return to the reservoir to relieve the pressure within the system.

Note: Reference OEM Service Guidelines for their specific hydraulic release system.

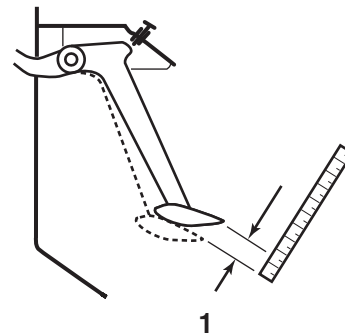

- Adjust Clutch Brake Squeeze for non-synchronized applications only.

- Example of hydraulic release system components:

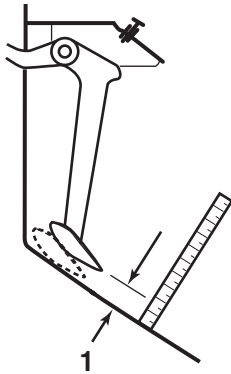

Clutch brake squeeze 0.500" to 1" (12.7 to 25.4 mm)

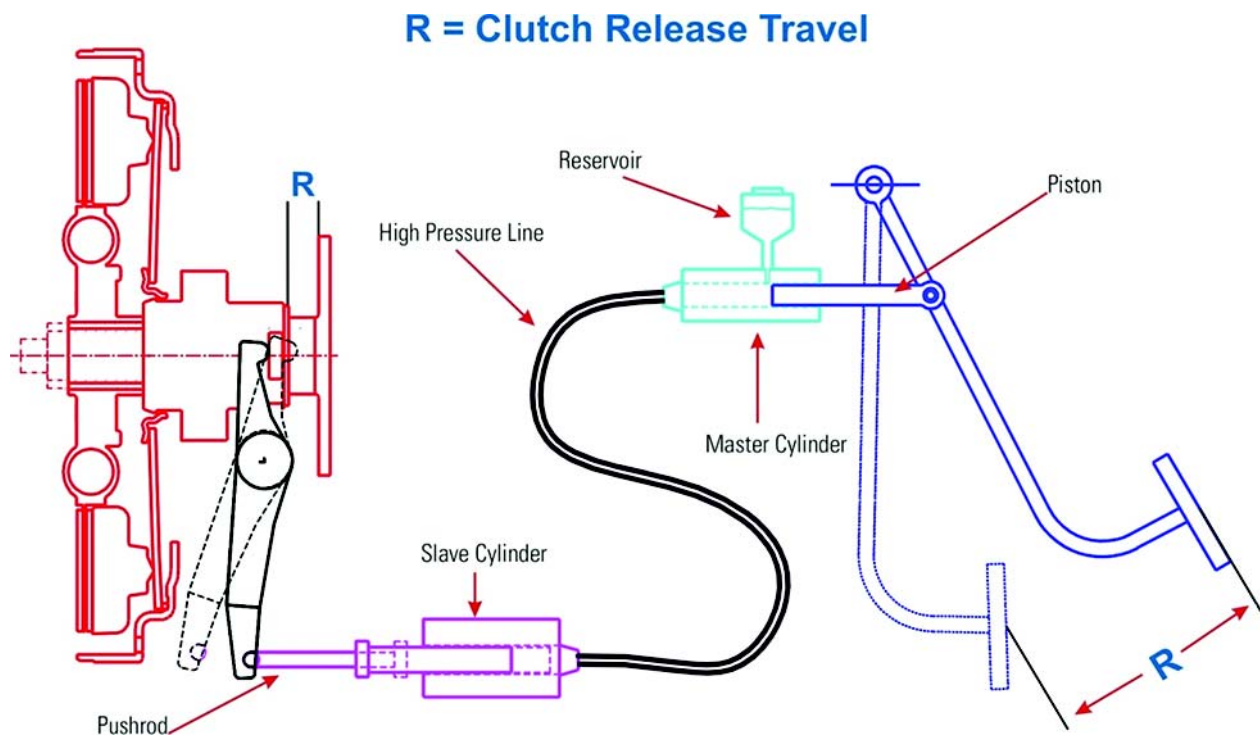

Advantage Lube Hose Assembly With Hydraulic Linkage

1. Install brass fitting into grease port on left side of release bearing housing using a Weatherhead socket. Tighten hand tight and continue to turn until the opening of the fitting is facing toward the 6 o'clock position.
2. Install lube hose into brass fitting and tighten until hand tight, then turn an additional two turns.

3. Lubricate release bearing until grease purges from release bearing housing. Use NLGI #2 or #3 Lithium complex grease.



Important: Eaton recommends the use of Roadranger EP2 for release bearing lubrication, or an equivalent Lithium Complex, NLGI #2 or #3 grease with a NLGI LB/GC performance rating and a dropping Point temperature of 220 C (428 F) or higher. Failure to use the proper grease may affect bearing life and void the warranty coverage on your Eaton product.



Important: If remote grease tube is utilized Eaton requires that the inspection cover be removed during greasing procedure to ensure that the release bearing is purging grease properly

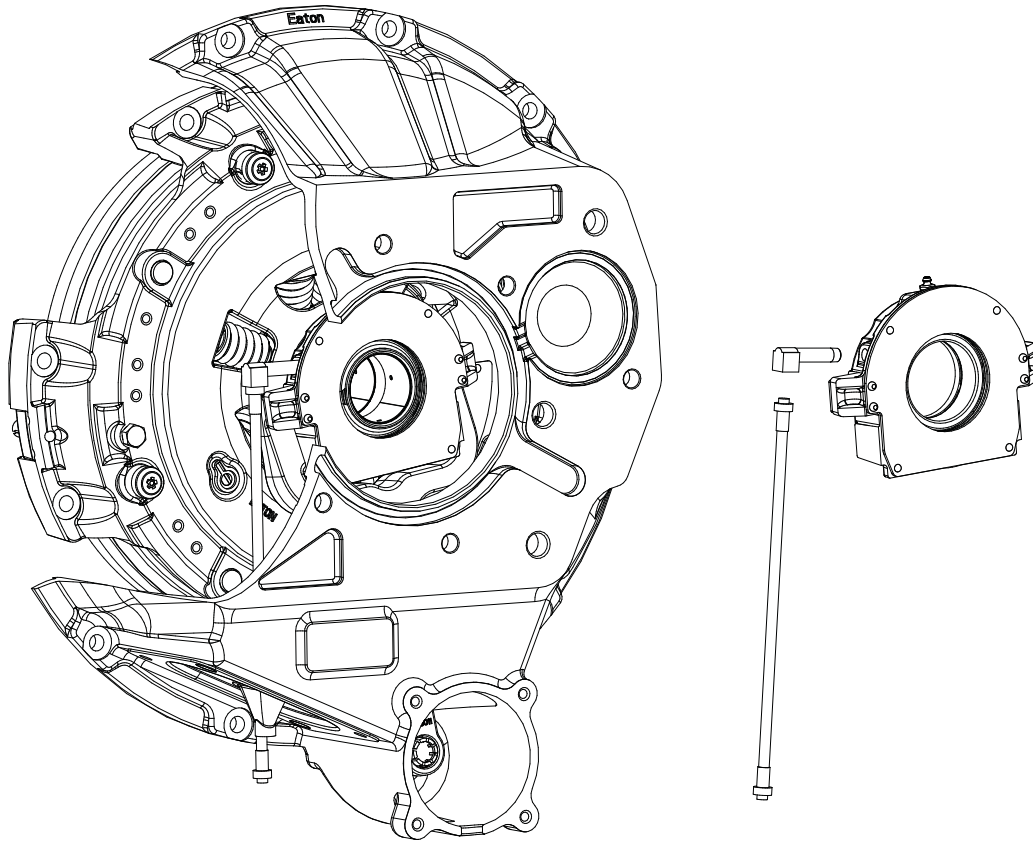

Parts Required:

1. K-4050 Lube hose assembly kit (includes brass fitting, lube hose, and plug)
2. A-8173 Hand hole cover with grommet

Pre-Advantage Series Clutch Lube Hose

1. Fitting is assembled to hose hand tight. Attach the brass fitting to the release bearing housing hand tight and turn fitting until opening of fitting is at the 9 o'clock position when facing the engine. Install the hose into fitting until hand tight and turn 1/6 turn. Refer to diagram.

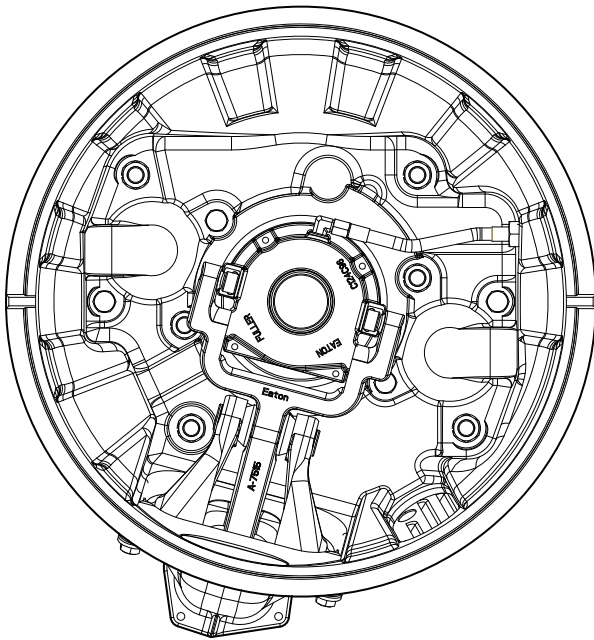

2. Transmission installation: remove the nuts from the brass fitting with the grease zerk. Install the transmission and insert the brass fitting through the hole in the left side of the clutch housing. Reinstall the brass nuts and tighten.
3. Lubricate release bearing until grease purges from release bearing housing. Use NLGI #2 or #3 Lithium complex grease.
! **Important:** Eaton recommends the use of Roadranger EP2 for release bearing lubrication, or an equivalent Lithium Complex, NLGI #2 or #3 grease with a NLGI LB/GC performance rating and a dropping Point temperature of 220 C (428 F) or higher. Failure to use the proper grease may affect bearing life and void the warranty coverage on your Eaton product.
4. Install 4305231 hand hole cover to protect the clutch from contamination.

General Clutch Information

Function of a Clutch

Any modern day clutch, whether designed for an automobile or heavy truck, performs several important tasks allowing for safe and convenient operation of the vehicle.

In a vehicle powertrain, the clutch is the device that interrupts the flow of power from the engine flywheel to the transmission. To start a gasoline or diesel engine, the flywheel must be able to turn freely without propelling the vehicle. By disengaging the clutch, the drivetrain is effectively disconnected from the rotation of the flywheel, allowing the engine to start.

Manual transmissions, whether synchronized (synchromesh) or non-synchronized (constant mesh), require an interruption of engine torque to complete a gear change. To make a gear change, the clutch pedal is depressed, breaking torque. This is followed by altering engine speed to more closely match the transmission input shaft (clutch disc) speed. After the proper gear is selected, the clutch pedal is then slowly released. As the clutch disc(s) are compressed, the relative slip speed between the flywheel and the transmission input shaft reaches zero and the clutch is completely engaged and capable of carrying full engine torque. With non-synchronized gearboxes, double clutching (a momentary partial engagement of the clutch made while the transmission is in neutral) is often necessary to allow rotational speeds of gears to become the same and complete the gear change.

With the advent of transmission automation, breaking torque and altering flywheel speed is accomplished via electronic throttle control and engine braking. The clutch pedal is used only when starting the engine, launching the vehicle from a stop, and slowing the vehicle to a stop.

The last function of the clutch is mitigating torsional vibrations. With any in-line, 6-cylinder engine there are three distinct power pulses occurring during each revolution of the flywheel. With each firing of a cylinder, the flywheel speeds up then slows down very quickly, resulting in a torsional vibration. This vibration can damage drivetrain components in short order if left uncontrolled. The coil springs in a driven disc damper absorb much of the vibration. The resonant (generally the least expensive drivetrain component) is considered the “fuse” of the system. Failure of a clutch damper section is usually an indication of a serious torsional vibration systems problem or shock loading due to driver abuse.

Clutches are assemblies made up of many different components utilizing many different types of materials. This section describes the major components which make up a complete Eaton clutch installation.

The following are the major components used to make up a clutch installation:

- Cover Assembly (contains pressure plate)
- Intermediate Plate (only in 2-plate clutches)
- Driven Disc(s)
- Clutch Brake

Neutral Idle Rattle

Neutral idle rattle is a system issue. It occurs when the engine is idling with the transmission in neutral and the clutch pedal in the up position. As the engine idles, the firing pulses cause the flywheel to oscillate as it is rotating. This oscillation is transmitted through the input shaft and into the transmission gearing. This oscillation causes the transmission gears to impact one another, resulting in a sometimes objectionable noise. While this noise is an annoyance, it is in no way damaging to the transmission and other components.

In the past, free travel dampers have been used to overcome this phenomenon. As systems have changed, in terms of mass, inertia and fuel injection pressures, free travel has become a less effective means of control.

Free travel, simply stated, is the free left or right rotation of the driven disc hub before engaging the clutch damper. This first stage isolates some of the flywheel oscillation energy and prevents or reduces the idle rattle.

Pre-damper technology is now available in some medium- and heavy-duty clutch applications and performs the same function as the free travel. By adding a dampened first stage, it is more effective at limiting neutral idle rattle. Generally, the pre-damper springs are very small and softer in rate than the main damper springs.

In diagnosing neutral idle rattle complaints, first try to fully depress the clutch pedal. This will disconnect the engine from the transmission. Second, try raising the engine idle speed with the clutch pedal up. This may smooth out the engine firing and may reduce, or eliminate, the noise.

If you have neutral idle rattle, determine what clutch is installed in the vehicle. It may already have a pre-damper clutch in it. If it is already equipped with a pre-damper clutch, then there is no benefit to changing the clutch.

Self-Adjusting Clutches

The Eaton Self-Adjusting is the industry's first adjustment-free clutch. With every push of the pedal, the innovative wear-adjusting technology senses for wear and makes any adjustments necessary.

Why There Is No Need to Adjust Eaton Self-Adjusting Clutches

If the Self-Adjusting Clutch is properly installed and the linkage is set-up properly, the Self-Adjusting Clutch should never need internal or external adjusting.

The Self-Adjusting Clutch automatically keeps the proper release bearing position and clutch free pedal position with two opposing cams. As the Self-Adjusting Clutch wears, the cams separate from each other, keeping the proper release bearing position. This in turn maintains the proper clutch free pedal position.

How It Works

Eaton Self-Adjusting Clutches wear-adjusting technology comes from two sliding cams. With every push of the pedal, the clutch senses for wear and makes any adjustments necessary. The cams rotate to maintain the proper adjustment throughout the life of the clutch. On top of the upper cam, a clutch wear indicating tab mirrors the cam movement to let you know when it's time to replace the clutch. The result of constant adjustment is greater longevity and a reduction in maintenance and labor costs.

Clutch Disc Dampening Characteristics

A key function of a clutch is to mitigate naturally occurring vibrations of the engine flywheel from reaching the transmission and the other components further down the drivetrain. This is accomplished by employing torsional spring dampers to the clutch pack. These springs take the form of coil springs, configured inside the clutch disc, that compress with the application of torque. The torque path through the damper begins at the friction interface at the facings, proceeds to the steel carrier disc and moves into the disc reinforcing plates where the springs are located. The springs are compressed, transmitting force to the spring covers which are rigidly attached to the hub. Torsional rate is defined as the amount of torque required per degree of center hub rotation. There are three basic categories of torsional rates for clutch dampers: rigid, standard and soft.

Rigid and Clutch Discs: Rigid discs and clutch discs with no spring package whatsoever act as a nearly direct link from the engine flywheel to the transmission and offer no protection against torsional vibration. Their use should be limited to older, mechanically fueled engines where clutch replacement cost is paramount over long component life. Rigid clutch discs are never used in new OEM applications.

Standard Dampers: Standard dampers include all 10-spring and most 8-spring types. The springs used in these dampers are approximately 1.5" long and do not offer a large amount of deflection before coil lock takes place. While these dampers were completely adequate for most heavy-duty applications several years ago, they are generally incapable of reducing the engine flywheel vibrations developed with slow speed electronically fueled engines. The use of standard dampers in heavy-duty applications has virtually ceased in OEM applications. The trend is to use more capable soft-rate dampers.

Soft-Rate Dampers: Soft-rate dampers, like the heavy-duty 7-spring and VCT Plus, offer much better protection against engine flywheel induced torsional vibrations. Their springs are characteristically longer than springs used in standard rate dampers and offer more deflection before coil lock occurs. This larger spring deflection is equated to lower torsional spring rate. With lower torsional rate, the resonant frequency of the complete drivetrain is lowered, usually to a point of a few hundred RPM below normal engine operating range. With the addition of hysteresis or Coulomb dampening (the energy expelled as the damper is exercised), the magnitude of the vibrations is reduced further, adding to the dampers benefit.

Pre-Damper: Pre-Damper is a feature designed for reducing idle rattle noise in various applications, where torsional vibrations are growing more erratic. That is why Eaton is now introducing the latest option for heavy-duty applications, the VCT Plus PD, where “PD” stands for Pre-Damper. The Pre-Damper consists of seven small springs surrounding the hub that reduce idle rattle when operating at low torque or engine speed with the transmission in neutral, prior to operation of the primary damper stage.

Clutch Disc Friction Material

Organic facings, often called “rag” facings, get their name from the high concentration of organic rubber and binder agents that make up their composition. Fiberglass cord (or similar material) is woven into the material matrix and adds burst strength and improves friction and wear properties. Asbestos has not been used in organic friction material since the early 1980s. Organic facings are used without exception in passenger car and light truck applications. This is because of smooth engagement properties and the relative light torque loads imposed on the clutch. In general, organic friction material lacks in performance in wear rate, coefficient of friction (ability to carry torque) and resistance to fade (abuse tolerance) when compared to cera-metallic friction material. The use of organic friction material in heavy vehicles has significantly declined over the past decade. Wear life and its maximum limit to 1400 lb-ft (1892 N•m) of torque in 15.5" clutches are the primary reasons.

Cera-metallic (ceramic) friction facings are composite material (copper, sand and other friction modifiers and binder agents). The dry raw materials are mixed in bulk, poured into die cavities, compressed, sintered in a controlled atmosphere, then brazed into a steel backer plate to facilitate rivet attachment to the driven disc. Compared to organic friction material, cera-metallics have improved performance in the areas of wear rate, resistance to fade (abuse tolerance) and coefficient of friction (ability to carry torque). It is for this reason that cera-metallics make up the vast majority of OEM builds.

Clutch Slippage

Slippage will cause significant heat build-up and rapid wear of the clutch pack. If the clutch pack temperature raises beyond the facing threshold temperature, the facing may disintegrate. Slippage is the result of loss of clamp load due to lack of adjustment, loading the clutch beyond its design torque rating or the clutch has reached the end of its design life. With the ability to re-rate an electronic controlled diesel engine, it is quite easy to deliver torque to the clutch beyond its design capacity. Before an engine re-rating is performed, confirm that the clutch and other drivetrain components are capable of carrying the increased torque and power.

Clutch Torque Capacity

It is imperative to understand the factors that influence friction force because this device transmits torque via friction. The fundamental equations that describes friction is:

$$F(f) = \mu N$$

Where $F(f)$ = Force due to friction

μ = Coefficient of friction

N = Load applied to the friction interface

$$T = F(f)r$$

Since torque (T) is equal to force friction [$F(f)$] multiplied by the moment arm (R), distance from application of force to center of rotation must be known. To exactly calculate the moment arm, the mean radius of a clutch (R), integration must be performed. However, for clutches in the size range offered by Eaton, the calculation can be simplified to:

$$r = (ID + OD) / 4$$

Clutch Wear

Clutch wear happens because the clutch discs slip relative to the engine flywheel and the pressure plate surface, and in the case of a 2-plate clutch, the intermediate plate, during vehicle launch and gear change. As the clutch disc friction material and mating flywheel and pressure plate surfaces wear, the gage thickness of the clutch pack decreases (moving the pressure plate closer to the engine flywheel). This movement of the pressure plate causes the pressure spring(s) to elongate and loose clamping load. If clamping load is allowed to decrease beyond a critical point, the clutch will be unable to carry full engine torque and slip.

Cover Assembly

The cover assembly, constructed of either stamped steel or cast iron, is bolted to the flywheel. It contains the pressure plate, which is fitted to the cover with pressure springs. It also contains the release bearing and levers, which move the pressure plate back and forth, thereby making or breaking contact with the disc assembly.

Driven Disc

Eaton offers a variety of 14" and 15.5" driven disc designs. The selection of driven discs depends on many factors.

Excessive torsional vibration can significantly reduce the life of all drivetrain components. That is why Eaton has engineered soft-rate dampers to reduce critical vibrations in today's electronic, high horsepower engines. Eaton recommends the use of soft-rate dampers (7-spring or VCT Plus) for all vehicles over 1,000 lb-ft.

Specifically, Eaton offers driven discs with different numbers of springs in the center section of the damper. 7-, 8-, 9- and 10-spring configurations are available. The proper selection depends on many factors, including the engine, flywheel and transmission of the vehicle.

Facings

The disc facings are critical to clutch life and performance because they directly receive the torque of the engine each time the clutch is engaged.

In general, ceramic facings have greater heat tolerance and torque capacity than organic facings. As such, they engage quicker, reduce slippage and deliver longer life.

Organic facings (non-asbestos) are adequate for lower horsepower, on-highway applications. However, Eaton recommends ceramic facings for most applications.

Intermediate Plate

The intermediate plate or center plate, increases the torque capacity of the clutch by providing additional surface area for facing material and torque capacity. The intermediate plate is driven by the clutch cover or by the flywheel on the 14" Easy-Pedal Plus[®] design.

Positive Separator Pin[™]

Eaton's Positive Pin Separator improves clutch life and performance by providing cooler operation, smoother engagement and equal plate separation. The pin restricts intermediate plate movement when the clutch is released, giving constant gap on both sides of the plate, therefore, allowing the driven discs to spin freely.

6-Position Kwik-Adjust[®]

Eaton's Easy-Pedal Plus 14" and Easy-Pedal[™] 2000 15.5" Clutches feature the Kwik-Adjust component and the easy-to-reach external manual adjustment mechanism that allows for quick adjustment of release bearing travel without the use of special tools or the need to remove any bolts. Using a common box end wrench, simply depress the Kwik-Adjust bolt and turn the standard 6-point hex head adjuster as needed.

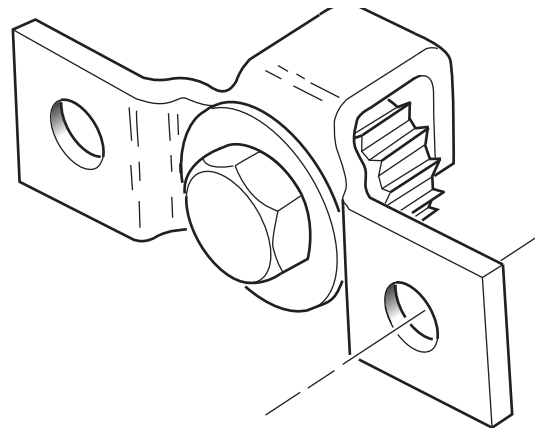

Part Number: 125489

Clutch Brakes

Clutch brakes are designed to extend the life of a vehicle transmission by eliminating damaging gear clash while reducing the effort required to shift into first or reverse from a standstill. Eaton offers two separate clutch brake options.

- Torque Limiting
- Kwik-Konnect[®]

Torque Limiting Clutch Brake

The Eaton Torque Limiting Clutch Brake has a self-contained torque limiting feature which prevents tang breakage from driver misuse of the clutch brake.

- Part Number 127740: 1.75" spline
- Part Number 127760: 2" spline

Kwik-Konnect® Two-Piece Clutch Brake

The two-piece clutch brake provides cooler operation than competitive clutch brakes. It is designed for service applications and can be quickly installed without removing the transmission.

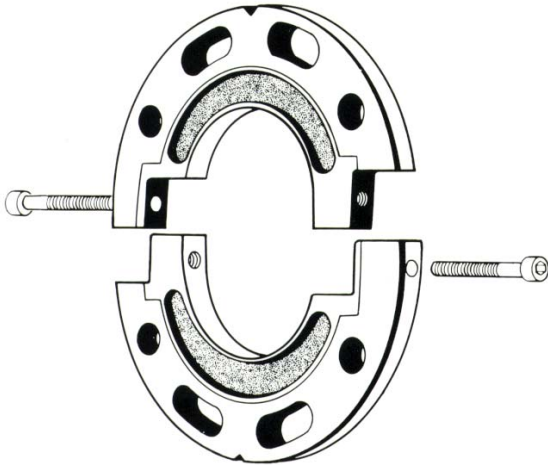

Part Number: 127200

Factors That Affect Clutch Performance

Excessive slipping is the major cause of clutch failure. Extreme operating temperatures can cause the clutch to fail because the heat generated between the flywheel, driven discs, intermediate plate and pressure plate is high enough to cause the metal to flow and the friction material to be destroyed.

An improperly adjusted or slipping clutch will produce sufficient heat to rapidly burn up.

There are many factors that have significant impact on clutch life:

- Application (torque capacity)
 - GCW/Weight
 - Number of starts per day
 - Maintenance/Adjustment
1. **Starting the Vehicle in the Proper Gear:** The correct gear will allow you to start the vehicle with your foot off the throttle.
 2. **Gear Shifting Techniques:** Many drivers up shift into the next gear or even skip shift into a higher gear before the vehicle has reached the proper speed. This type of shifting is almost as damaging as starting off in a gear that is too high, since the engine speed and vehicle speeds are too far apart, requiring the clutch to absorb the speed difference as heat.
 3. **Excessive Vehicle Overload or Overloading the Clutch:** Clutches are designed and recommended for specific vehicle applications and loads. These limitations should not be exceeded. Excessive or extreme overloading is not only damaging to the clutch but to the entire vehicle powertrain as well. If the total gear reduction in the powertrain is not sufficient to handle excessive overloads, the clutch will suffer, since it is forced to pick up the load at a higher speed differential.
 4. **Do Not Ride the Clutch Pedal:** Riding the clutch is very destructive to the clutch since a partial clutch engagement permits slippage and excessive heat. Riding the clutch pedal will also put a constant thrust load on the release bearing, which can thin out the lubricant and also cause excessive wear on the pads. Release bearing failures can often be attributed to this type of operation.
 5. **Do Not Slip the Clutch to Hold the Vehicle on an Incline:** This procedure uses the clutch to do the job normally expected of the wheel brakes. A slipping clutch accumulates heat faster than it can be dissipated, resulting in early failures.
 6. **Do Not Coast With the Clutch Released and Transmission in Gear:** This procedure can cause high driven disc RPM through multiplication of ratios from the final drive and transmission. It can result in “throwing” the facing off the clutch discs. Driven disc speeds of over 10,000 RPM have been encountered in such simple procedures as coasting tractors down an unloading ramp. While an ample safety factor is provided for normal operation, the burst strength of the facing is limited.
 7. **Do Not Engage the Clutch While Coasting:** This procedure can result in tremendous shock loads and possible damage to the clutch, as well as the entire drivetrain.
 8. **Reporting Erratic Clutch Operation Promptly:** Drivers should report erratic clutch operation as soon as possible to give the maintenance personnel a chance to make the necessary inspection, internal clutch adjustment, linkage adjustment and lubrications, thereby avoiding possible clutch failures and breakdowns while on the road. The importance of free pedal travel (sometimes referred to as a pedal lash) should be brought to the driver’s attention as well as the mechanic. This item should be included and commented on daily in the driver’s report, since clutch free pedal is the maintenance personnel’s guide to the condition of the clutch and the release mechanism.
 9. **Clutch Adjustments**
 - **Manual Adjustment:** The importance of proper and timely clutch adjustments and lubrication can not be overstated. Internally adjusting the clutch properly and when needed will keep the clutch components in the proper position and extend the life of the clutch. See the adjustment section for more information.
 - **Adjustment-Free:** If your truck is equipped with an Eaton Self-Adjusting Clutch, then the clutch will always be in proper adjustment. Possible lubrication and inspection are needed. See “Inspection and Lubrication”.

When to Inspect the Clutch

The clutch should be inspected during the regularly scheduled lubrication intervals as dictated in the Lubrication section or when one of the following occur:

- **Clutch Free Pedal:** If the clutch free pedal is one-half of OEM specifications, not less than 1/2". During normal clutch use, the release bearing will move toward the fork fingers and reduce "in cab" free pedal.
- **Clutch Is Slipping:** If the clutch is slipping, it may require adjustment. If proper internal (clutch adjuster) and external (clutch linkage) adjustment has been made and the clutch still slips, it is likely worn beyond its useful life and needs replacement.

Inspection for Clutch Life

Inspect for clutch life. If your vehicle is equipped with a Eaton Self-Adjusting Clutch, the clutch is equipped with a clutch wear indicating tab that can be seen through the inspection window. To calculate the expected life of a Self-Adjusting Clutch, apply a paint mark indicating the start point of the clutch wear indicating tab. Record the mileage when this mark was made. After a few months, reinspect the position of the clutch wear indicating tab and record the new mileage. The difference between the two readings can be used to estimate when the clutch will need to be replaced. For example:

Starting Mileage = 10,000

After 6 months mileage = 75,000

Clutch wear indicating tab movement = 0.625" (16 mm)

75,000–10,000 = 65,000 miles

65,000 miles/.625" = 104,000 miles per inch of tab movement

3.5" remaining tab movement

3.5" remaining tab movement x 104,000 miles per inch of tab movement = 364,000 expected clutch life

Designing a Clutch for a Specific Application

There are three parts to designing a clutch for a specific application. If the correct clutch is chosen, the truck will have good engagement, protection for the driveline, long clutch life and minimal loss of torque.

Check the Flywheel Bore (15.5" Clutch): The flywheel environment must be checked to make sure a clutch can be used with it. The bore is important when deciding what type of driven disc to use. The bore must be large enough to allow for a proper fit of the disc. See chart below.

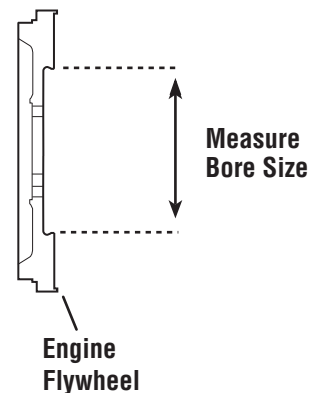

No. of Springs	Bore Size	
8-Spring	7 1/4"	(184.15 mm)
10-Spring	8 9/16"	(217.48 mm)
7-Spring	9 3/4"	(247.65 mm)
9-Spring*	9 3/4"	(247.65 mm)

*Mack/Volvo Engine 2007 and newer only

Torque Capacity: A clutch must be chosen that has a torque capacity that is greater than or equal to the peak torque of the engine. This is very important today when an engine can be easily adjusted electronically to produce greater torque. There are two factors in determining torque capacity. These two factors are friction force and damper capacity:

- Friction force is a product of the cover assemblies clamp load (also called plate load). This factor was explained in the previous section, and is stated as $F(f) = uNPr$. Determining the friction force is important because if this force is not greater than or equal to the peak torque of the engine, the clutch will slip.

- Damper capacity is what allows the clutch to provide torsional protection for the entire driveline. If the peak engine torque exceeds this capacity, the driveline will be abused. This abuse will cause faster wear and possible destruction of driveline components. Since damper capacity is a product of the springs used in the damper, changing the number and type of springs changes the stiffness of the entire system.

Application: Service replacement clutches should have the same plate loads, damper and friction material. Substituting from the original could shorten the life of the clutch and drivetrain components.

Preventive Maintenance Overview

To ensure long life and proper operation of the release mechanism of the clutch, it is important to properly lubricate the following areas.

Lubrication

1. **Release Bearing:** The cast iron bearing housing will be equipped with either a standard grease fitting or a lube tube extension. If a lube tube is not present, it is necessary to remove the inspection cover to gain access to the grease fitting. Apply grease until it purges from the rear of the housing. Grease on the clutch brake friction surface and the transmission input shaft will extend the life of the clutch brake and bronze bushings inside the release sleeve.
2. **Release Bearing Wear Pads:** Where the release fork contacts the bearing housing, there are small hardened steel pads. Apply a small amount of grease to the wear pads where the clutch release fork contacts.
3. **Clutch Brake:** The clutch brake friction material is designed to operate with lubricant. While lubricating the release bearing, grease should purge from the housing and contact the clutch brake. This is beneficial for long clutch brake life. If desired, a small amount of grease could be applied to both sides of the clutch brake.
4. **Cross-Shaft Bushings:** Lubricate both the left and the right cross-shaft bushings per OEM recommendations.
5. **Clutch Control Linkage:** Lubricate the clutch linkage bell cranks and pivot pins per OEM recommendations.
6. **Pilot Bearing:** The pilot bearing inside the flywheel is a sealed for life bearing and requires no lubrication. Use a premium pilot bearing to prevent clutch drag and early bearing failures (C-3, C-4, C-5 Suffix).

Lube Tube Assembly

The Eaton Lube Tube Assembly enables the release bearings in Eaton medium- and heavy-duty clutches to be greased without removing the bell housing inspection cover. The lube tube hose replaces the original zerk fitting on the release bearing and protrudes through the bell housing window.

Lube Tube Lengths

Length in Inches	Part Number
12"	CLT012
9"	CLT009
8"	CLT008
7"	CLT007
6"	CLT006

Lube Hose Kits/Assemblies for Hydraulic Release System

Kit/Assembly	Description
K-4050	Used with Advantage clutches
A-7857	Used with Non-Advantage series clutches

Recommended Lubrication



Important: Eaton recommends the use of Roadranger EP2 for release bearing lubrication, or an equivalent Lithium Complex, NLGI #2 or #3 grease with a NLGI LB/GC performance rating and a dropping Point temperature of 220 C (428 F) or higher. Failure to use the proper grease may affect bearing life and void the warranty coverage on your Eaton product.



Caution: Incorrect grease and improper lube procedures will cause bearing failures, bushing wearout, and yoke tip and bearing wear pad wear.

For a list of recommended lubricants, see TCMT-0020 or call 1-800-826-HELP (4357).

Lubrication Interval

The UltraShift DM clutch does not require any lubrication or adjustment. There is no clutch linkage associated with this product, therefore there is no linkage adjustment or maintenance requirements.

For recommended lubrication intervals, see TCMT-0021 or call 1-800-826-HELP (4357).

Grease Compatibility – Eaton Clutch Products

Greases available to the trucking industry are not created equal, and many are formulated for specific applications. Just reading the information on the label on the container may not be enough to determine if the greases that are being used by our customers for maintenance is compatible with greases used in Eaton clutch products. The following information will provide details of what to look for when selecting a grease for Eaton Clutch Release Bearings, effects on the product

What to Look for When Selecting Grease

1. Look for these three things:
 - Grade
 - Thickener Type
 - Performance
2. Greases are considered “compatible” when these parameters don’t change when mixed:
 - Grade (Consistency): If the grease becomes softer.
 - Lower Heat Resistance: If the grease melts sooner.
 - Decrease in Additive Performance: If the grease does not protect as well.

Note: Even though incompatibility is not predictable, certain types of thickener combinations often have been found unsatisfactory and are recognized as incompatible.

Eaton Clutch Grease Service Requirements

1. Grade: National Lubricating Grease Institute (NLGI) #2.
2. Thickener Type: Lithium Complex.
3. Performance: NLGI LB/GC.
4. Eaton Clutch Service Lubrication Requirements: Proper greasing is the key to clutch longevity. Proper grease intervals purge the debris from the grease and provide new grease for bearings. Consult the appropriate Clutch Service Manual for a detailed explanation of the lubrication techniques.

Incompatible Grease Usage

The use of a grease that is not compatible with the Road-ranger® Grease EP-2 Lithium-Complex grease can result in premature release bearing failures.

General Information

Failure to properly lubricate the bearing/bushing will result in bearing and bushing failures.

- Regular grease service intervals are required to purge the debris from the grease.
- If not maintained, the debris can become hard and prevent the flow of grease when serviced.

Below are examples of failures due to incompatible greases.

The first example is the release bearing where the majority of the grease has disappeared. This is likely due to using grease with a lower operating temperature. When the release bearing gets hot, the grease “melts” and does not provide adequate lubrication.



Release Bearing Failure

The second example is a release bearing with grease that is contaminated with debris. It is very important to grease at regular service intervals to purge the debris from the bearing.

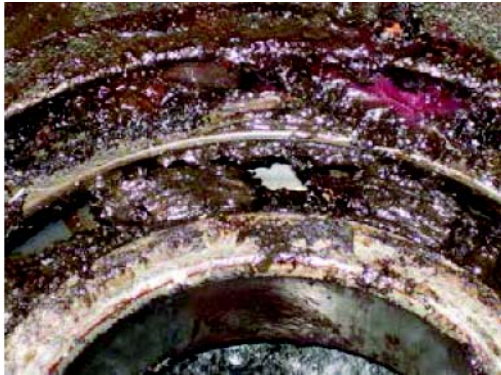

Grease Contaminated With Debris

The third example is a close-up of the debris in the grease. The debris is damaging to the bearing and will cause premature failures.

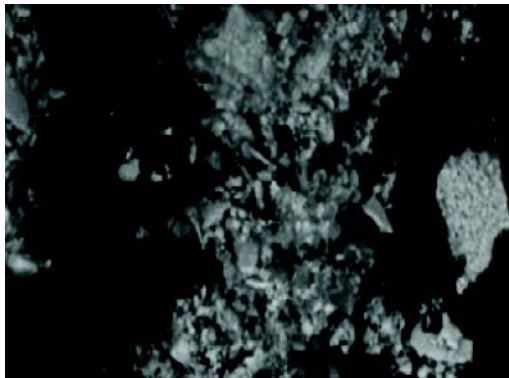

Debris Close-up

Grade (Consistency)

The NLGI grade of grease refers to its consistency. It is measured by dropping a weighted cone into the grease per ASTM D217. The depth the cone penetrates into the grease is called the consistency. The NLGI grade refers to a range of depths the cone penetrates into the grease.

This chart is a helpful reference to understand the consistency and appearance of a grease based on the NLGI Grade.

NLGI Grade	Appearance	Consistency
000	Fluid	Cooking oil
00	Fluid	Applesauce
0	Very soft	Brown mustard
1	Soft	Tomato paste
2	Moderately soft	Peanut butter
3	Semi-fluid	Vegetable shortening
4	Semi-hard	Frozen yogurt
5	Hard	Smooth p�ate
6	Very hard	Cheddar cheese spread

Grease Thickener Type Incompatibility (Observations of Failed Clutch Release Bearings)

- Lowered Heat Resistance occurred when mixing two incompatible thickener types. By lowering the heat resistance of the grease mixture, the clutch release bearing failed prematurely.
- The data below show the maximum operating temperature of two greases and of a 50/50 mixture of the greases:
 - Lithium Complex Type Grease: 486°F
 - Calcium Sulfonate Type Grease: 486°F
 - 50/50 mixture: 310°F
- The reduction in the maximum operating temperature of the mixture shows that the two greases are not compatible.

Note: Calcium sulfonate type greases are not compatible with Lithium complex types. Use of Calcium sulfonate type greases will reduce the life of Eaton Clutch release bearings.

Performance

NLGI developed designations and performance descriptions for service grease categories. These categories are defined per ASTM D4950 and include the lubrication of wheel bearings and chassis components.

An “L” designation includes such things as ball joints, steering pivots, universal joints and other chassis components, and a “G” designation includes wheel bearing greases. Each class (L and G prefix) are further divided into categories based on service needs. The most demanding service category is designated by defining both classes (L and G) and the highest alphabetical nomenclature for the class. The GC-LB service category defines a multi-purpose grease suitable for both chassis and bearing service applications.

The symbol below is provided from NLGI to designate the service performance quality of a grease. It is not always found on the packaging. Often, a reference to the specification is found on the product datasheet.



L–Designation is for chassis components.

G–Designation is for bearings.

Roadranger® Grease EP-2

This grease is multi-purpose, high performance NLGI Grade 2 lithium-complex grease used for a variety of on and off road applications, where the use of conventional lithium grease is limited.

Datasheet for Roadranger Grease EP-2

Characteristics	Test Methods	Roadranger® Grease EP-2
NLGI grade	ASTM D-217	2
Thickener type		Li-Complex
Color		Blue
Texture		Smooth
Dropping point, °C	ASTM D2265	274
Base-oil viscosity, cSt	ASTM D445	
100° C		15.6
40° C		150
Four ball wear, scar diameter, mm	ASTM D2266	0.41
Fretting wear, mg	ASTM D4170	5.1

Application

Roadranger Grease EP-2 is highly recommended for lubrication of U-joints, tripods, drive shafts, clutch release bearings, release sleeve bushings and brakes with high temperature conditions. Its excellent low temperature behavior makes it suitable for extreme climate conditions around the world. Roadranger Grease EP-2 has excellent anti-friction properties in order to reduce shudder. It is also suitable for machinery used in construction, dredging, forestry, marine, and mining where this type of grease is required.

Benefits

- Meets NLGI GC-LB (Chassis and Wheel Bearing) requirements.
- Roadranger® U-joint and clutch requirements.
- Improved extreme pressure and rust protection.
- Copper and iron corrosion resistance.
- Extended bearing life.
- Provides greater “wash off” resistance.
- Performs in high and low temperatures.
- Excellent elastomer compatibility.
- Recommended operating temperatures between -40°C (-40° F) and +150°C (302° F).

Datasheet for Roadranger Grease EP-2

Characteristics	Test Methods	Roadranger® Grease EP-2
Rust test, rating	ASTM D1743	Pass
Copper corrosion, rating	ASTM D4048	1A
Wheel bearing leakage, grams	ASTM D4290	4.0
Bearing life performance, hours	ASTM D3527	140
Water resistance at 80° C, % removed	ASTM D1264	3.9
Low-temperature torque at -40° C	ASTM D4693	9.7
Elastomer compatability	ASTM D4289	
ASM3217/3B CR type 70 hours @ 100° C		
Volume Change, %		14
Hardness change, durometer A, pts.		-6
ASM 3217/3B NBRL type 70 hours @ 150° C		
Volume change, %		10

Clutch Guide for Eaton Clutch Products

Special Instructions

None

Special Tools

None

Eaton Clutch Products

1. Inspect the transmission front bearing cap for wear.



2. Replace if bearing cap is worn.
3. A worn bearing cap can cause premature clutch brake failure.

4. Effect the clutch adjustment in achieving correct free pedal or clutch brake squeeze.

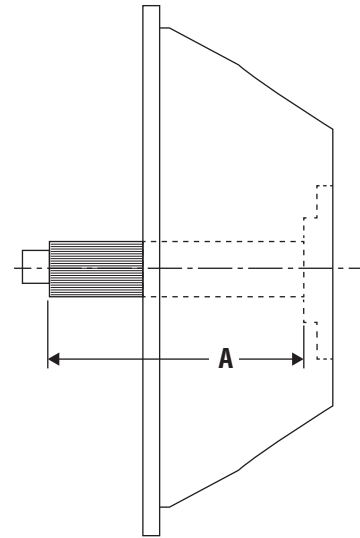

Dimension A for the transmission bearing retainer cap, based on SAE standards, is 8.657" (219.9 mm) nominal and should not be greater than 8.71" (221.5 mm). Ref. 1990 SAE handbook 4:36.106.

5. Clean the transmission input shaft and inspect for wear and nicks.



6. Check transmission input shaft for twist.



7. Take a driven disc and place on input shaft and slide the full length of the splines.
 8. If the disc hangs up on the splines replace the transmission input shaft.
 9. Inspect pilot on the end of the input shaft for wear.



10. Replace input shaft if worn.
 11. Install the transmission with the splines on the input shaft clean and dry. Do not use lubricants or anti-seize on input shaft splines.

12. Check to see if pilot bearing will fit onto the transmission input shaft prior to installing into the flywheel.



13. If the pilot on the input shaft does not fit the pilot bearing, it will be difficult to install the transmission.

14. Install the pilot bearing.



Caution: Drive on the outer race only when installing to flywheel. Driving on the inner race can damage the bearing race which can cause a bearing failure.



Caution: Do not damage the seals during installation.

15. Use premium bearing, Viton seals and high temp grease with a C3 or C5 bearing fit.



16. Check for fit to opening in flywheel.



17. Check inner race for movement.
18. A tight pilot bearing can cause failure of the pilot on the input shaft or a poor releasing clutch.
19. Inspect machined flywheels to ensure that the side of the pilot has not been machined.



20. Check the measurement of the top of the pilot from the friction surface of the flywheel. Ensure that the pilot has at least a .030" clearance from pilot on the clutch cover. Pilot depth on cover is $.277 \pm .010$ ".

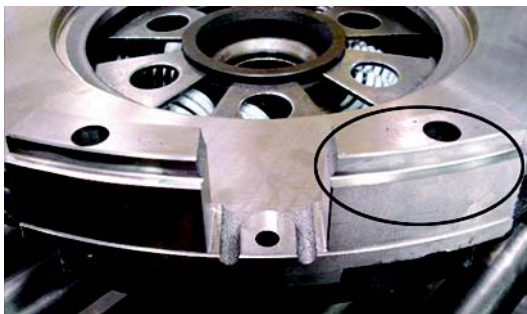

21. Check that flywheel flatness should be flat to .006" concave.

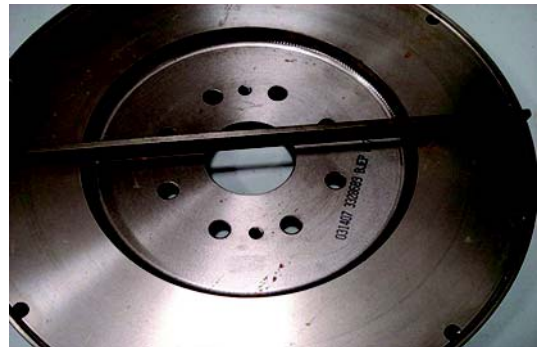

22. Be sure to properly align flywheel to dowels in crankshaft.
- Warning:** Failure to properly align the flywheel to the crankshaft will cause excessive runout of the flywheel.



23. Measure Engine Flywheel, see page ****.

- Flywheel face: Maximum .008"
- Pilot bearing bore: Maximum .005"
- Flywheel housing I.D.: .008"
- Flywheel housing face: .008"

24. Clean grease, oil, rust preventative and dirt from flywheel friction surface and mounting bolt area.



Important: Contamination on the flywheel can cause the clutch to either slip or not release.

25. Place flywheel disc on flywheel can check for any interference with opening or flywheel mounting bolts.



- 26.** If the damper of the disc does not fit the flywheel bore, the clutch will not release, and you will not be able to get correct clutch adjustment.
- 27.** Inspect the cross shaft installation, shaft should be flush to recessed. If the cross shaft is protruding through the release fork, you will not be able to install transmission.

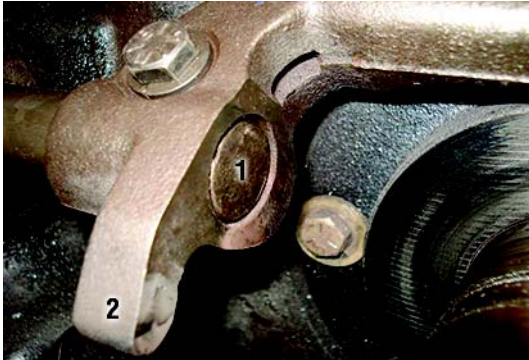

1. Cross Shaft
2. Fork Fingers

- 28.** Check release fork fingers for wear, replace if worn. A worn release fork will affect the ability to set up clutch adjustment correctly.
- 29.** Install clutch pilot interface to flywheel pilot. Support the heavy weight of the 15.5" clutch assembly to ensure that the pilot of the clutch positions inside of the pilot of the flywheel.



- 30.** Tighten mounting bolts in a crisscross pattern starting with a lower bolt. Reference below manuals for specific information.

- 31.** Use guide studs to support the clutch. Clutches are heavy and the use of guide studs (upper mounting holes) will help support the clutch while the clutch mounting bolts are installed and torqued. The use of guide studs will also help with alignment of the pilot on the clutch cover to the pilot of engine flywheel.



- 32.** The use of a clutch jack similar to the one picture is recommended, because a 15.5" clutch weighs about 145 lb. Use of a clutch jack will also assist in getting the clutch cover pilot into the pilot of the flywheel.

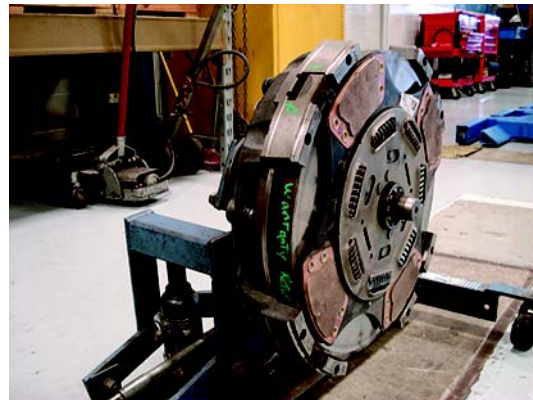

33. Use alignment shaft during clutch mounting to flywheel to align the hubs of the driven disc to the center of the flywheel and make installation of the transmission easier:



- For the Self-Adjust Clutch, while removing the shipping bolts, push upwards on the alignment shaft.
- For the Easy-Pedal Clutch, push upward on the alignment shaft while tightening the clutch mounting bolts.



34. Set the four separator pins with a flat nose punch and a small ball peen hammer, 15.5" clutch pictured. Reference either the CLSM-0100 or CLSM-0200 for specific locations of separator pins for the product being installed.



35. Install the clutch brake. It is non-directional, and it does not matter which side faces toward the transmission. The clutch brake is only utilized when the vehicle is stationary, when shifting into a start gear.

Caution: Do not use the clutch brake to bring the vehicle to a stop or make gear selections while the vehicle is in motion.



36. For clutch set up, check the release bearing travel (distance between release bearing and clutch brake):
- Easy-Pedal .500" to .560"
 - Self-Adjust .490" to .590"
37. To check clutch brake squeeze, use a .010" feeler gauge placed between release bearing and clutch brake. Depress clutch pedal to floor and verify if feeler gauge can not be pulled out.
38. Release fork free-travel 1/8" (gap between release fork finger and wear pad on release bearing housing).
39. Using feeler gauges, fill gap on both side of release fork fingers, between release fork fingers. Resistance to pull feeler gauges should be equal.
40. Measure total stack-up of feeler gauges and divide by 2. This will be the gap at the release fork finger. If not within the following range, the linkage will need to be adjusted ($.125" \pm .020"$). For clutch service evaluation, refer to clutch service bulletin CLIB-0014.

Eaton Clutch Performance Evaluation and Set-up

Special Instructions

None

Special Tools

None

Validating Clutch Release Bearing Travel with a Clutch Brake

1. Stroke the clutch pedal from its uppermost stop to the floor or firewall to check for any binding or restrictions that may restrict proper movement of the clutch release bearing.
2. Apply a light force on the clutch pedal to take up the clearance between the clutch release fork and the wear pads on the release bearing housing.

3. Using an appropriate measuring tool, measure the gap between the clutch release bearing housing and the clutch brake.

Note: The tool used for taking this measurement should be of a type that can provide a valid measurement, e.g., telescoping gage, transfer dividers, verified thickness gage.

Note: This measurement should be 0.500" to 0.560" for a manually adjusted clutch and 0.490" to 0.560" for a Self-Adjust Clutch.

Note: If using a thickness gage or solid bar, do not force the bar between the clutch release bearing housing and the clutch brake, as this may give an inaccurate measurement of the gap between the release bearing and the clutch brake.

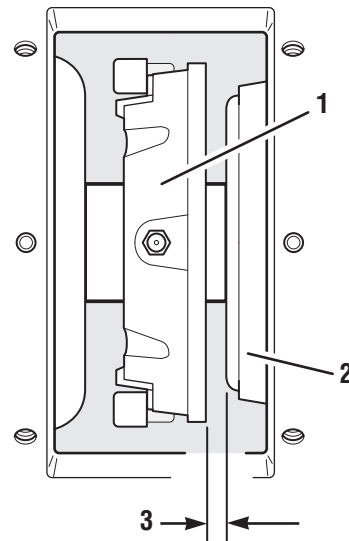

1. Release Bearing
2. Clutch Brake
3. 0.500"–0.560" (12.70–14.22 mm)

Installing Clutch Inspection Hand Hole Cover

Over the years, it has been the practice in the trucking service industry when servicing Eaton clutch products the hand hole inspection cover is not being reinstalled. Not reinstalling the clutch inspection cover after servicing of the clutch will leave a large opening which will allow contamination to be ingested into the clutch housing and the clutch itself. This contamination can lead to clutch performance issues such as seized adjusting rings, seized cams, release bearing failures and general performance complaints.

Failure Mode Examples

Dirt ingestion into the pressure spring area of the clutch can lead to seized adjusting rings or cams and clutch performance issues.



Dirt ingestion into release bearing can result in release bearing failure.



Contamination that resulted in the adjusting ring seizure.

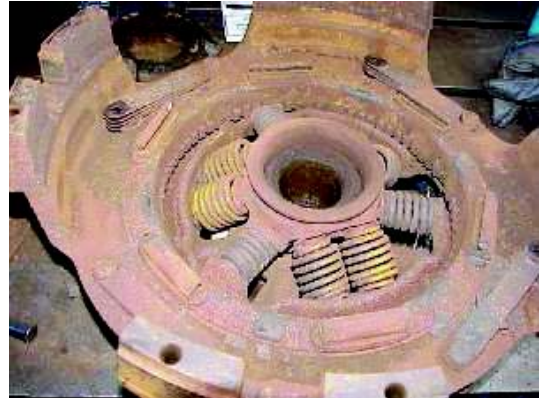

Recommended Practice

After servicing Eaton clutch products, it is important to reinstall the clutch inspection cover so that ingestion of dirt or contaminants into the clutch environment does not occur. Below are two hand hole covers that are available through Eaton if the hand hole cover is missing.

Part number 4305231 is recommended if a release bearing lube hose is not utilized.



Part number 4305230 is recommended if a release bearing lube hose is utilized.



Part number A-8173 is recommended for off-highway or extreme conditions where a lube hose is utilized.



Fastener Requirements

The fasteners required to secure the hand hole cover to the clutch housing are two bolts at 5/16" x 18 x 1/2".

Note: If customer is still experiencing issues with contamination ingestion into the clutch environment with the hand hole cover in place, the vehicle should be evaluated for additional sources of ingestion. An example of items to inspect are unused holes in engine flywheel housing clutch housing.

Machining of Pressure Plate and Intermediate Plate of 2250 lb-ft Rated Clutches

Eaton clutches rated at 2250 lb-ft are not widely used in the North American trucking market. Customers who have not seen one of these clutches may question the machining of the pressure plate and the intermediate plate as it is physically different than all other rated clutches.

On this high-capacity rated clutch, the pressure plate and intermediate plate are first machined concave on the outer portion of both plates and then are ground flat (see pictures indicating proper machining appearance). This more precise manufacturing process is required to better control the contact area of the driven disc facings at the outer radius of the pressure plate and the corresponding intermediate plate. Having full contact at the outer radius of both plates will ensure the clutch does not slip during the initial clutch break-in period.

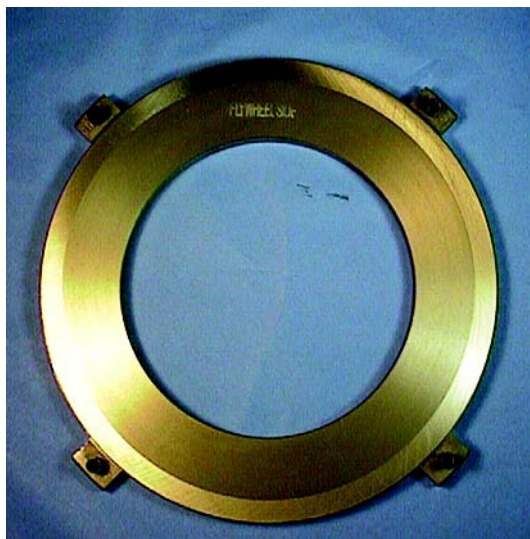

Copyright Eaton, 2017.

Eaton hereby grant their customers, vendors, or distributors permission to freely copy, reproduce and/or distribute this document in printed format. It may be copied only in its entirety without any changes or modifications. THIS INFORMATION IS NOT INTENDED FOR SALE OR RESALE, AND THIS NOTICE MUST REMAIN ON ALL COPIES.

Note: Features and specifications listed in this document are subject to change without notice and represent the maximum capabilities of the software and products with all options installed. Although every attempt has been made to ensure the accuracy of information contained within, Eaton makes no representation about the completeness, correctness or accuracy and assumes no responsibility for any errors or omissions. Features and functionality may vary depending on selected options.

For spec'ing or service assistance, call 1-800-826-HELP (4357) or visit www.eaton.com/roadranger. In Mexico, call 001-800-826-4357.

Roadranger: Eaton and trusted partners providing the best products and services in the industry, ensuring more time on the road.

Eaton
Vehicle Group
P.O. Box 4013
Kalamazoo, MI 49003 USA
800-826-HELP (4357)
www.eaton.com/roadranger

Printed in USA

Roadranger

EATON
Powering Business Worldwide